

# Turner PRO

**molift**<sup>®</sup>  
by Etac

EN - User manual

IT - Manual utente

DE - Gebrauchsanweisung

FR - Manual d'utilisation

NO - Brukermanual

ES - Manual de usuario

SV - Bruksanvisning

NL - Handleiding

FI - Käyttöohje

DK - Brugsvejledning

BM61099 Rev G 2029-12-29

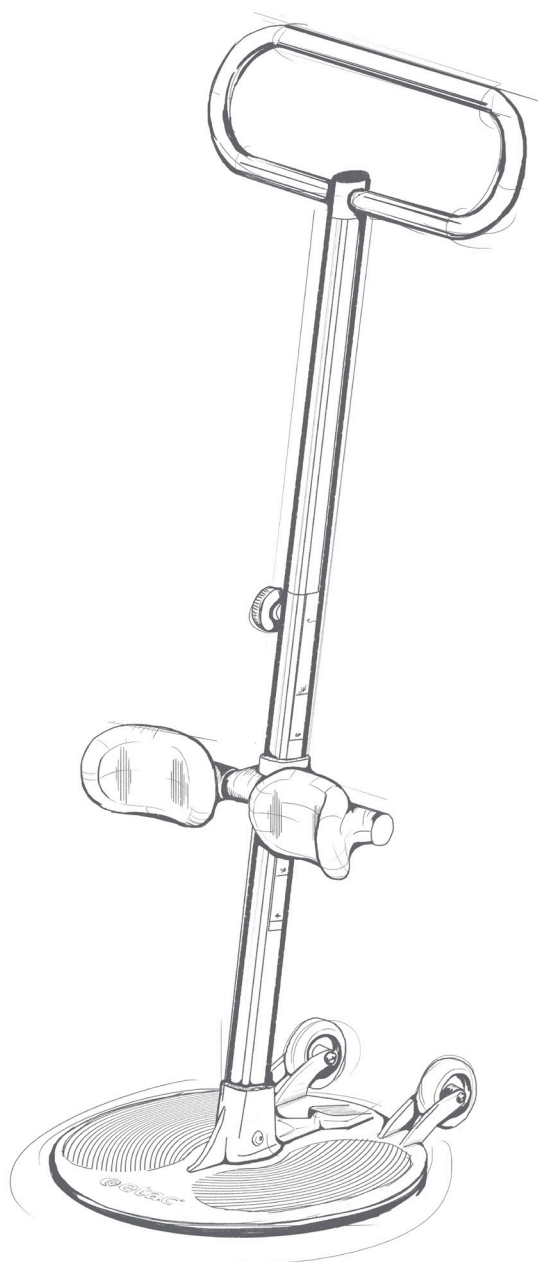

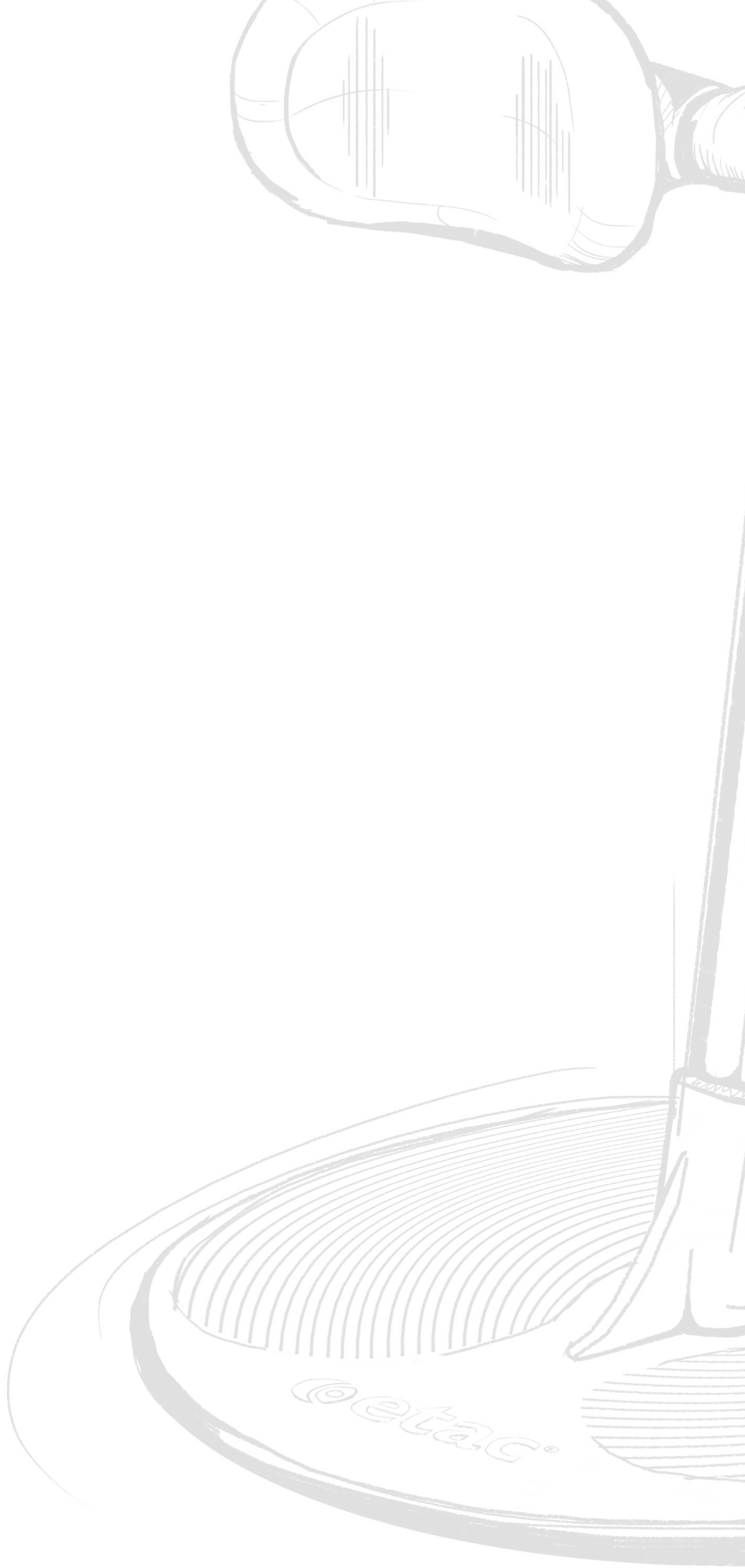



## Contents

User manual - English	- 4
Bruksanvisning - Svenska	- 8
Brukermanual - Norsk	- 12
Brugsvejledning - Dansk	- 16
Käyttöohje - Suomi	- 20
Gebrauchsanweisung - Deutsch	- 24
Handleiding - Nederlands	- 28
Manual d'utilisation - Français	- 32
Manual utente - Italiano	- 36
Manual de usuario - Español	- 40

General

CE declaration



The product, and its related accessories, described in this instruction for use (IFU), is in compliance with the regulation (EU) 2017/745 of 5. April 2017 – as a medical device, risk class I. The product is manufactured and tested according to EN 12182:2012 and selected parts of EN/ISO 10535:2006. Any serious incident that occurs in relation to the device should be reported to the manufacturer and the competent authority of the Member State in which the user and/or patient is established.

Conditions for Use:

Transferring a person may pose an element of risk. Only trained personnel should use the equipment covered by this user manual.

Warranty notice

Two-year warranty against defects in workmanship and materials of our products.

Please refer to www.etac.com for terms and conditions.

Visit www.etac.com to download the latest version of our documentation.

Important

This User Manual contains important safety instructions and information regarding the use of the Turner PRO and accessories. In this manual the user is the person being transferred. The assistant is the person operating the Turner PRO.



This symbol indicates important information related to safety. Follow these instructions carefully.



**Read User Manual before use!**  
It is important to fully understand the content of the user manual before attempting to use the equipment.

Modifications and use of components made by other manufacturers:

We recommend only using Etac components and spare parts. Declaration of conformity is not valid and Etac is not responsible for warranty if any modifications are made to the product. Etac shall not be liable for faults or accidents that can occur when using components made by other manufacturers.

Risk assessment

Assess the risk and take notes.

You as the assistant are responsible for the safety of the user!



Only technical personnel are allowed to perform repairs.

Labels and symbols

Product label:

The label contains art. number and serial number (bar codes). The EAN code contains;

(01) (EAN no.): xxxxxxxxxxxxxx

(11) (Batch): YYMMDD

(21) (Serial number): xxxxx



Symbols:

Symbols used on the product, explained in more detail:



Manufacturer



Date of manufacture



Catalogue number



Serial number



Medical Device



CE marked



Refer to user manual



Max temperature when washing



Max user weight (SWL)



pH when washing



QR code

Short user guide:

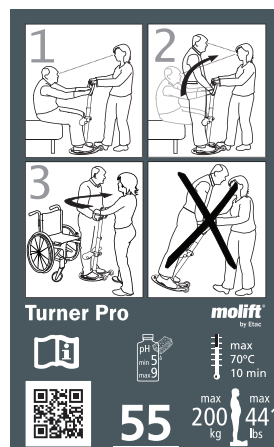

Turner PRO - intended use

Turner Pro is a sit-to-stand transfer aid that makes it easier for a carer to help a user to stand and transfer him/her to another sitting position. Users must be able to grip and pull up their own body weight, but still require support/help to stand up and be turned. The purpose is to transfer a person from/to bed, chair, wheelchair or toilet. The Turner PRO is lightweight and easy to move around. The Turner PRO should only be used indoor on flat surfaces.

Turner PRO

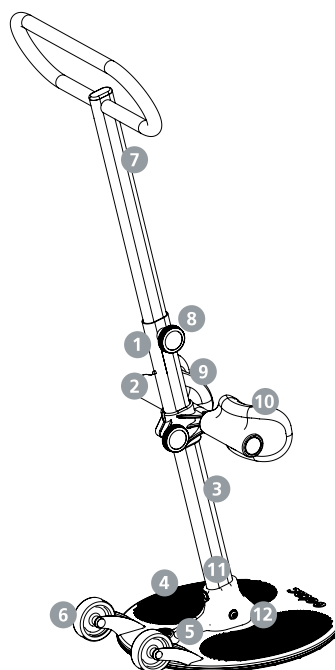

1. Outer pole
2. Lock pin
3. Height label
4. Main plate
5. Assistant footrest
6. Transport wheels
7. Inner pole with handle
8. Turning knob
9. Short user guide
10. Leg support
11. Product label
12. Bolts

### Technical data

**Safe Working Load (SWL):**

200 kg (441 lbs)

**Weight of unit:**

8kg

**Dimensions:**

- Height (A): 0,8-1,2 m
- Height (B): 0,3-0,55 m
- Depth (C): 0,46 m
- Width (D): 0,45 m
- Footplate (Ø): 0,40 m

**Material:**

Powder coated aluminum, Plastic, Steel.

**Expected Lifetime:**

The Turner PRO has an expected lifetime of 5 years or 15000 turning cycles

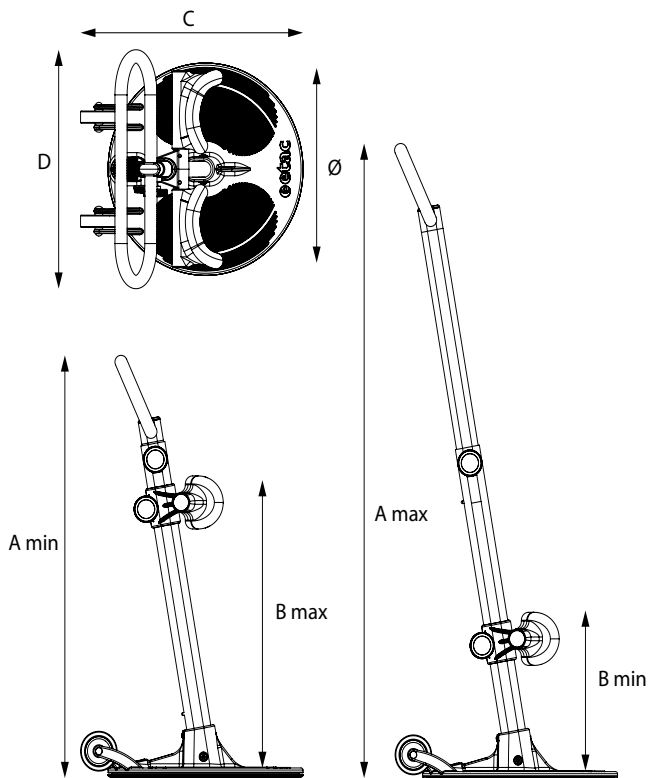

### Mounting leg support

The knee cushions are adjusted individually. The leg support has step-less adjustment from 0,3 to 0,55 meters. Follow these two steps when mounting the leg support:

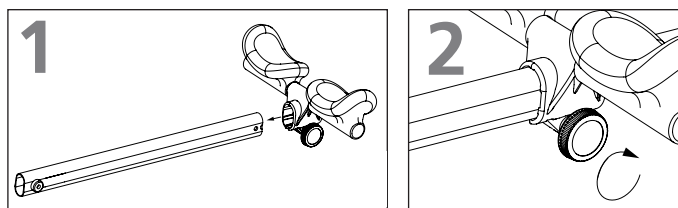

Lay the pole down on an even surface. Insert leg support with kneepads pointing upwards. Make sure both knobs are on the same side.

Tighten knob by turning knob clockwise.

### Mounting pole to main plate

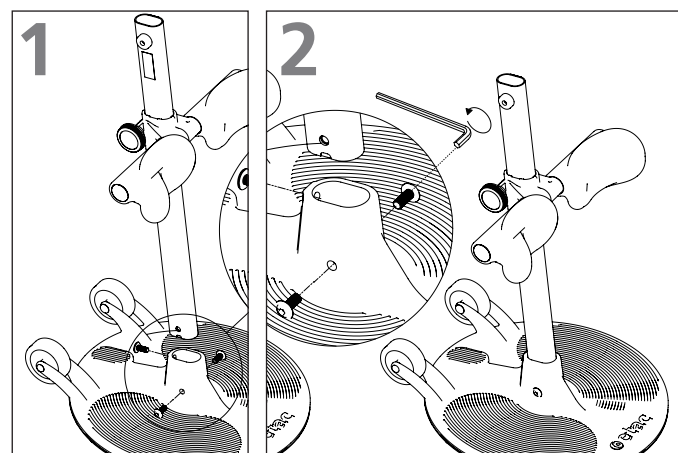

Place the base plate on an even surface. Insert pole with knee pads facing away from the wheels.

Insert all three screws into holes in the base plate. Use allen key to screw in bolts. Tighten bolts firmly.



**Make sure that all three bolts are properly fastened. Loose bolts can make the pole wobbly and the Turner PRO unsafe to use.**

### Supplied parts

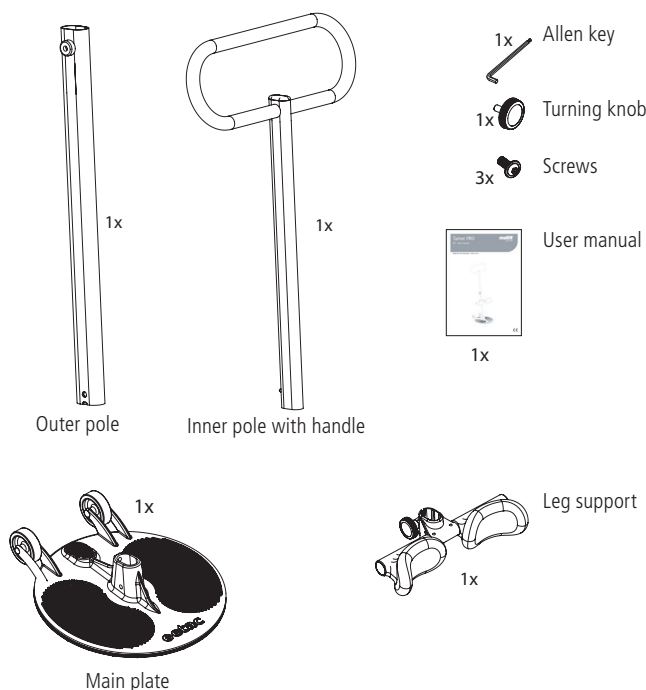

### Mounting handle

The handle has step-less adjustment from 0,8 to 1,2 meters. Follow these three steps when mounting the handle:

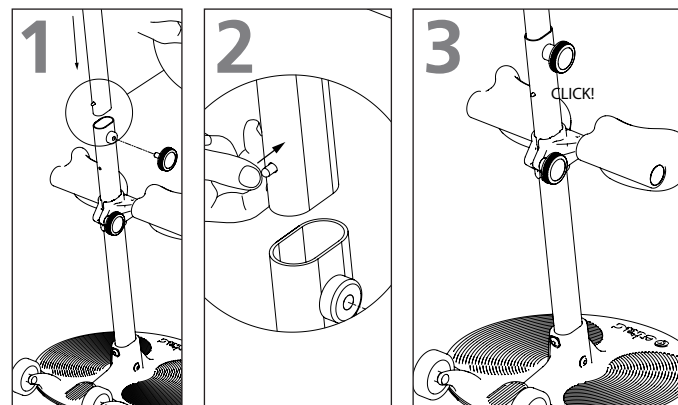

Place the handle with the lock-pin pointing towards the wheels.

Press in the lock pin and slide the pole into the mounted pole.

There will be a clicking sound when it is correctly mounted. Turn and tighten the knob.

### Checklist after assembly



**Don't start using Turner PRO before completing the checklist after assembly.**

Use this checklist to verify that the Turner PRO is properly installed and can operate correctly and safely before use. See assembly information on the previous page for details.

- Make sure that the leg support is mounted correctly.
- Make sure that all three bolts between outer pole and main plate are mounted correctly and properly tightened.
- Make sure that the handle (inner pole) is mounted correctly.
- Make sure Turner rotates freely.

### Adjusting handle height

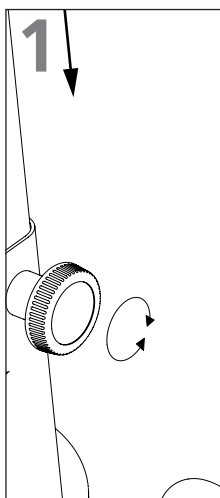

1 Turn knob counter clockwise and adjust handle height.

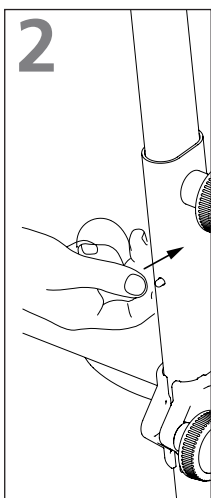

2 Push the lock pin in if the handle is in upper position.

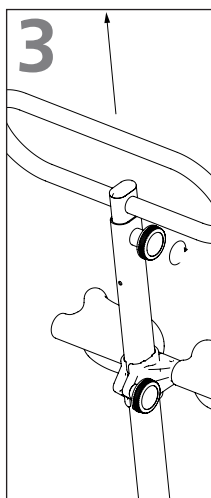

3 When correct handle height is obtained, turn knob clockwise to lock the position.



**Be aware of handle when adjusting height. Handle can slide down and hit operators head or upper body.**



**Don't use handle in a position above the lock pin position. This makes the pole wobbly and the Turner unsafe to use.**

### Adjusting leg support height

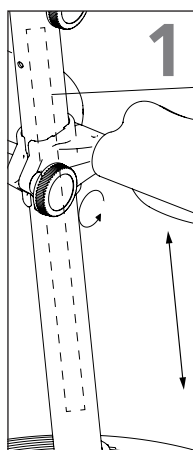

1 Turn knob anti clockwise and adjust knee support height.

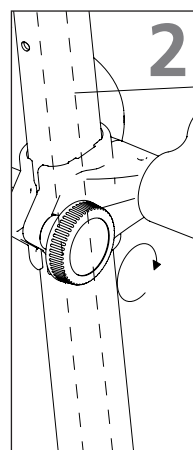

2 When correct knee support height is obtained, turn knob clockwise to lock the position.

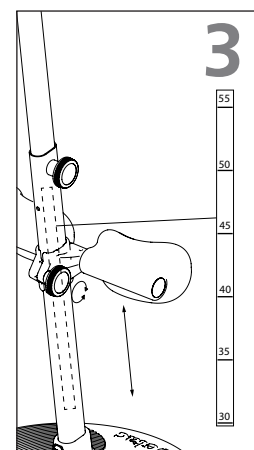

3 The knee support height can be read from the scale on the pole. The number above the leg support bracket refers to the correct height.



**Make sure knobs are securely tightened. Loose knobs can cause handle or knee support to slide down and make the Turner unsafe to use.**

### Positioning Turner PRO



1 Position the new seat (chair, wheelchair, toilet or bed) in an 90 degree angle with the existing seat.

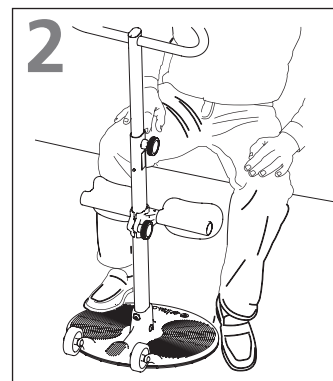

2 Slide the Turner PRO in under the users feet.

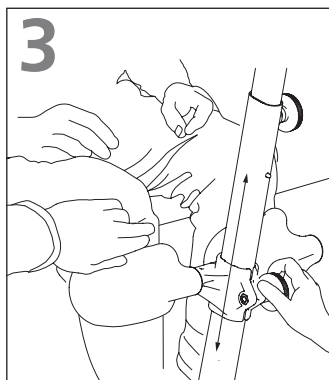

3 Adjust the height of the leg support so it is positioned two fingers beneath the users knee cap.

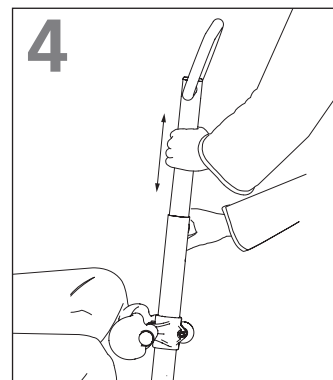

4 Adjust the height of the handle to a position that is comfortable for both user and assistant.

**Transport and storage**

Turner PRO can be stored and transported under temperatures between -25 - 70 °C and relative humidity between 15 - 93 %

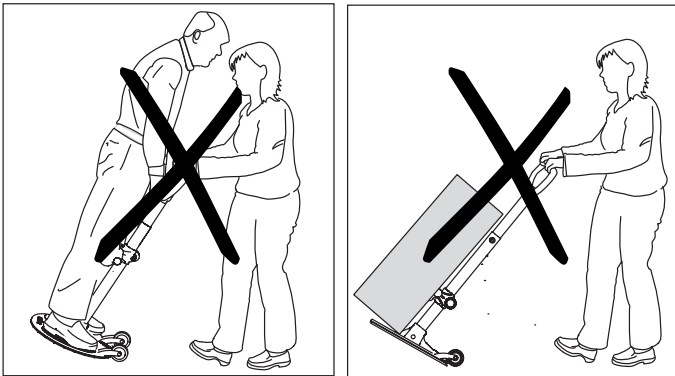

 Don't use the Turner Pro for transportation of people or goods.

**Transferring user**

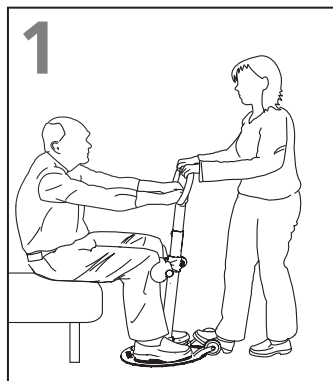

Grip the handle with both hands and place one foot on the foot rest. The user grips the handle, if possible with both hands.

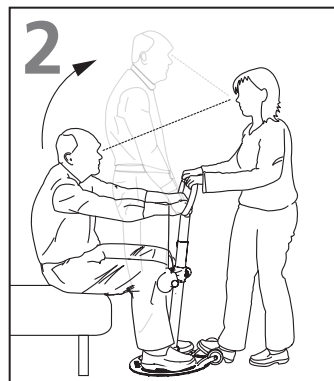

Encourage the user to stand up, at the same time, counter-balancing the users weight using a foot and hands (use your bodyweight by leaning backwards).

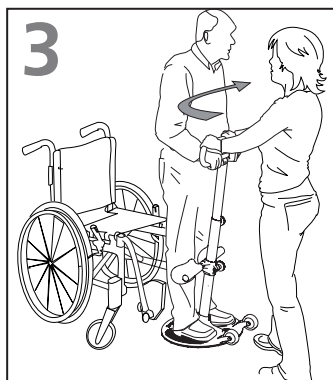

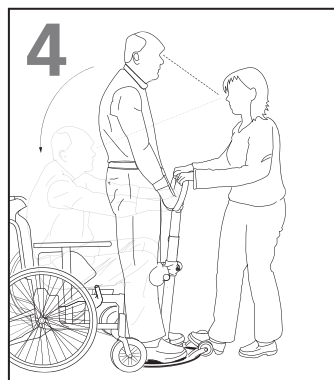

Twist the Turner PRO so that the user is transferred to the front of the new seat.

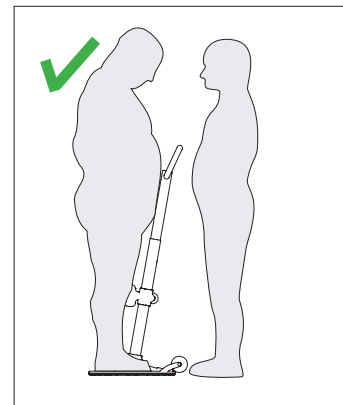
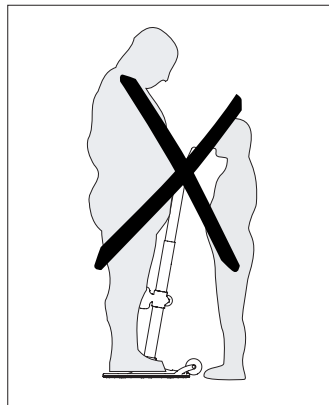

Step on footrest, brace your weight and ask the user to sit down. Maintain eye contact with the user during the entire transfer process.

**User / Assistant**



 The assistant has to be able to handle the weight of the user.

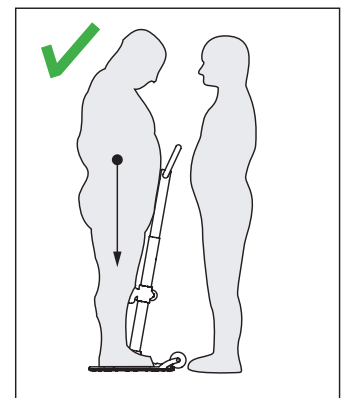
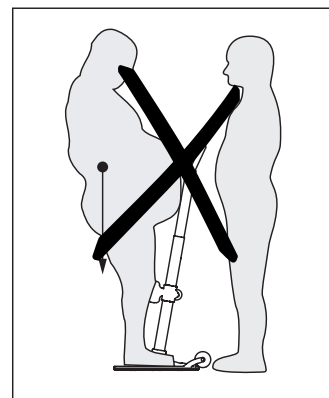

 Make sure the users weight is within the baseplate.

**Cleaning and disinfection**

Clean on a regular basis. Clean surfaces with a damp cloth using an appropriate pH-neutral detergent. Do not use solvents or strong liquids, this may damage surfaces on the Turner. For disinfection when needed; use isopropyl alcohol or similar. Avoid abrasive cleaning products. Remove hair and pile from the wheels and verify that the wheels rotates freely.

 Make sure not to damage or remove labels when cleaning.

**Reconditioning**

Follow cleaning and assembly procedure. Separate reconditioning document is available at Etac.com.

**Recycling**

Turner PRO can be disposed of as metal waste. Recycling instructions is available at Etac.com

**Spare parts**

A list of spare parts is available at Etac.com.

Allmänt

	<p><b>CE-märkning</b>                  Produkten och de tillbehör som beskrivs i denna bruksanvisning överensstämmer med förordning (EU) 2017/745 av den 5 april 2017 som medicinteknisk produkt, riskklass I. Produkten tillverkas och testas i enlighet med EN 12182:2012 och utvalda delar av EN/ISO 10535:2006.                  Alla allvarliga incidenter som inträffar och som är relaterade till produkten ska rapporteras till tillverkaren och den behöriga myndigheten i det medlemsland där användaren och/eller patienten bor.</p>
---	---

Villkor för användning:

Förflyttning av en person kommer alltid att utgöra en viss risk och endast utbildad personal får använda den produkt som omfattas av den här bruksanvisningen .

Garantimeddelande

Två års garanti mot defekter i utförande och material i våra produkter.

Se [www.etac.com](http://www.etac.com) för villkor. På [www.etac.com](http://www.etac.com) kan du ladda ned dokumentation så att du med säkerhet har den senaste versionen.

Viktigt

Denna bruksanvisning innehåller viktiga säkerhetsinstruktioner och information om användning av Turner PRO.

I den här bruksanvisningen är brukaren den person som förflyttas. Assistenten är den person som hanterar Turner PRO.

	<p>Denna symbol indikerar viktig information om säkerhet. Följ dessa instruktioner noggrant.</p>
---	--

	<p>Läs bruksanvisningen innan användning!                  Det är viktigt att till fullo förstå innehållet i bruksanvisningen innan du försöker använda utrustningen.</p>
---	---

Ändringar och användning av komponenter

tillverkade av andra tillverkare:

Vi rekommenderar att endast använda ETACS komponenter och reservdelar. Försäkran om överensstämmelse är inte giltig och Etac är inte ansvarig för garantin om några ändringar görs på produkten. Etac kan inte hållas ansvarig för fel eller olyckor som kan inträffa vid användning av komponenter tillverkade av andra tillverkare.

Riskbedömning

Gör en riskbedömning och dokumentera!

Assistenten är ansvarig för brukarens säkerhet.

	<p>Endast teknisk personal får utföra reparationer.</p>
---	---

Etiketter och symboler

Etikett:

Produktetiketten innehåller artikelnummer och serienummer. Streckkoden innehåller;

(01) EANnr: XXXXXXXXXXXXX  
 (11) Batch ÅÅMMDD  
 (21) (serienummer): xxxxx



Kortinstruktion:

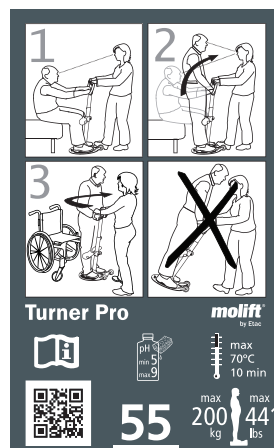

Symboler:

Symboler som används på produkten, förklaras mer i detalj:

-  Tillverkare
-  Tillverkningsdatum  
YYYY-MM-DD
-  Katalognummer
-  Serienummer
-  Medicinteknisk produkt
-  CE-märkt
-  Se bruksanvisningen
-  max 70°C 10min  
Max värme vid tvätt
-  max 200 kg max 441 lbs  
Max brukarvikt (SWL)
-  pH max 5 min 9  
ph vid tvätt
-  QR-kod

Turner PRO - avsedd användning

Turner PRO är ett uppresnings- och överflyttningshjälpmedel som förenklar uppresning och förflyttning från en sits till en annan. Används av brukare som har gripfunktion och klarar av att bära sin egen kroppsvikt, men behöver stöd/hjälp vid uppresning och förflyttning. Avsedd användning är förflyttning av en brukare från/till säng, stol, rullstol eller toalett. Turner PRO är tillverkad av lättviktsmaterial och kan lätt flyttas till nya platser. Turner PRO bör endast användas inomhus på plana ytor.

Turner PRO

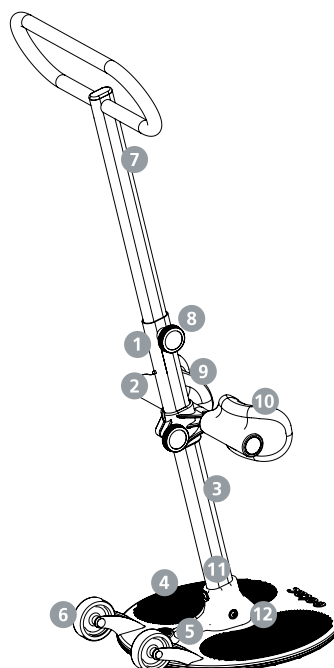

1. Nedre stång
2. Låspinne
3. Höjd etikett
4. Bottenplatta
5. Assistentens fotpedal
6. Transporthjul
7. Övre stång med handtag
8. Låsvred
9. Kortinstruktion
10. Benstöd
11. Produktetikett
12. Skruvar



## Teknisk data

## Max brukarvikt (SWL):

200 kg (441 lbs)

## Vikten av enhet:

8kg

## Mått:

Höjd (A): 0,8-1,2 m

Höjd (B): 0,3-0,55 m

Djup (C): 0,46 m

Bredd: 0,45 m

Fotplatta (o): 0 40 m

## Material:

Pulverlackerad aluminium, plast,  
Stål.

## Förväntad livslängd:

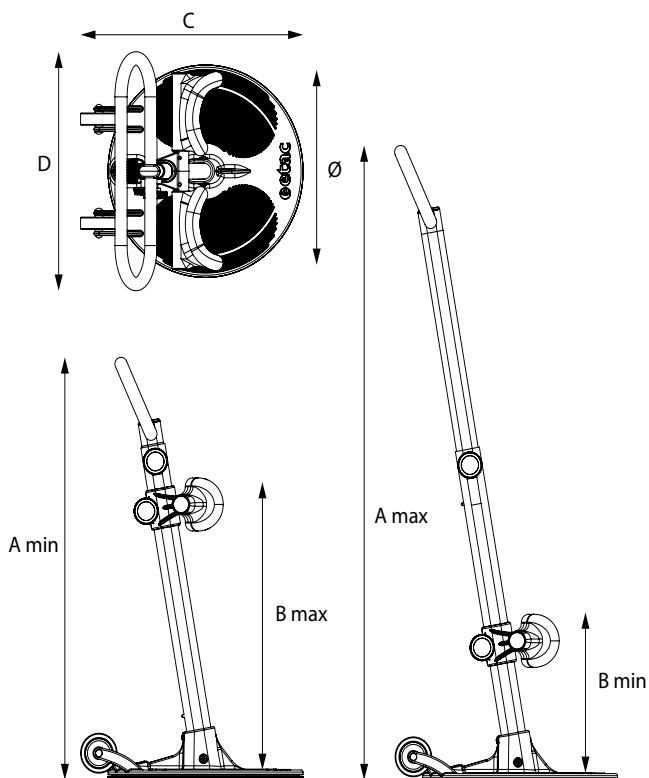
Turner PRO har en  
förväntad livslängd på fem  
år eller 15000 varvcykler

## Montering av benstöd

Underbensstöden är individuellt justerbara. Stolpen är steglöst justerbar från 0,3 till 0,55 meter. Följ dessa tre steg vid montering av benstöd:

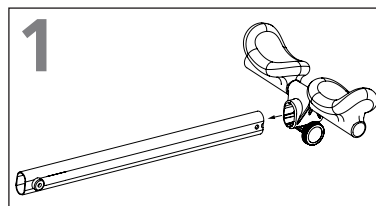

Lägg den nedre stolpen på en plan yta. Placera benstödet så det pekar uppåt. Kontrollera så att båda vreden är på samma sida.

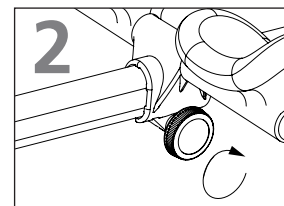

Drag åt genom att vrida vreden medurs.

## Montering av stolpen på bottenplattan

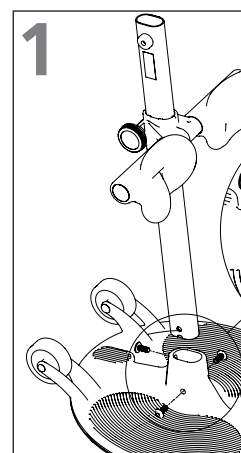

Placera bottenplattan på ett plant underlag. Infoga stolpe med benstöden vänd bort från hjulen.

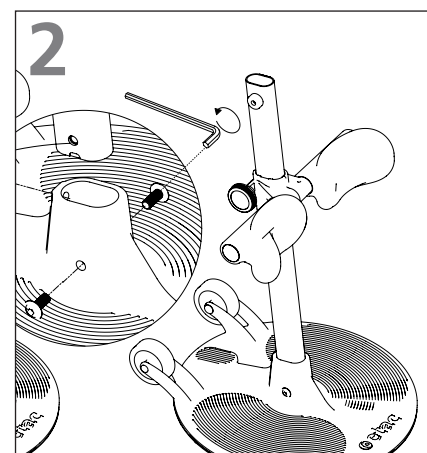

Sätt alla tre skruvar i hålen i bottenplattan. Använd insexnyckeln och drag åt skruvarna.



Kontrollera att alla tre skruvar är ordentligt åtdragna. Lösa skruvar gör stolpen instabil och Turner PRO osäker att använda.

## Medföljande delar



## Montering av handtaget

Handtaget är steglöst justerbar från 0,8 till 1,2 meter.

Följ dessa tre steg vid montering av handtaget:

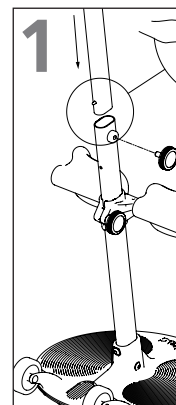

Placera handtaget med låspinnen så den pekar mot hjulen.

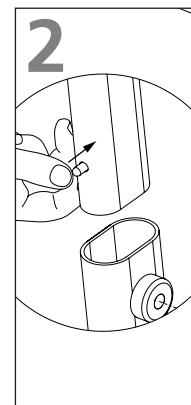

Tryck in låspinnen och tryck ned den övre stolpen i den nedre stolpen.

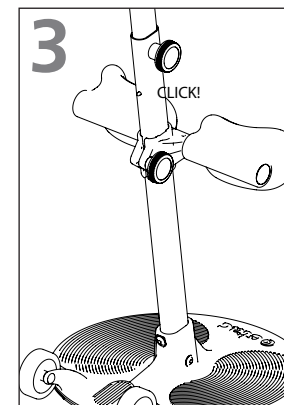

Det är korrekt monterat när ett klickande ljud hörs. Lås handtaget genom att dra åt vreden.

### Checklista efter montering



Börja inte använda Turner PRO innan du slutfört kontroll enligt checklista efter montering.

Före användning, använd denna checklista för att kontrollera att Turner PRO är rätt monterad och kommer att fungera korrekt och säkert, före användning. Se monteringsanvisning på föregående sida för mer information.

- Kontrollera att benstöden är korrekt monterad (1)
- Kontrollera att alla tre bultar mellan yttre stolpen och huvudplattan är monterad på rätt sätt och är ordentligt åtdragna. (2)
- Se till att handtaget (inre stängeln) är korrekt monterad. (3)
- Se till Turner roterar fritt.

### Justera handtagshöjd

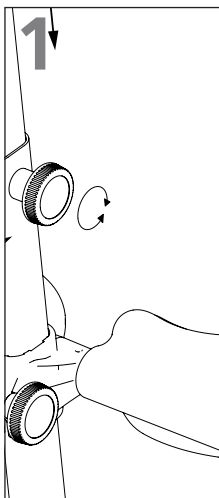

Vrid låsvredet moturs och justera handtagshöjd.

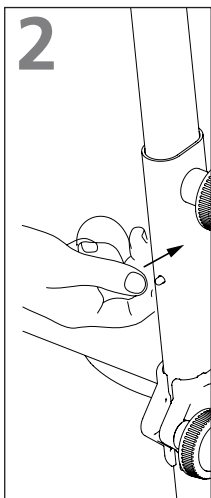

Skjut in låspinnen om handtaget är i sitt övre läge.

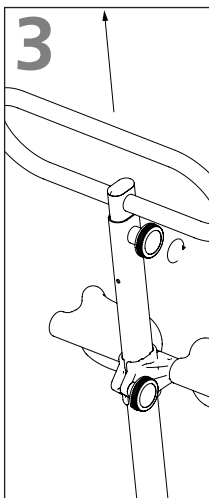

När rätt handtagshöjd erhålls vrid ratten medurs för att låsa positionen.



Var uppmärksam vid justering av handtagets höjd, det kan glida ner och skada assistenten eller brukaren.



Använd inte handtaget i ett läge ovanför låsspringen. Det gör stolpen vinglig och Turner osäker att använda.

### Justering av benstödens höjd

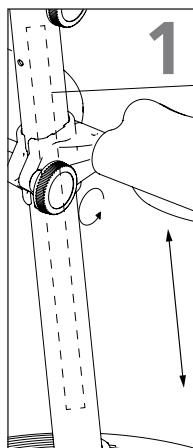

Vrid låsvredet moturs och justera knästöds höjd.

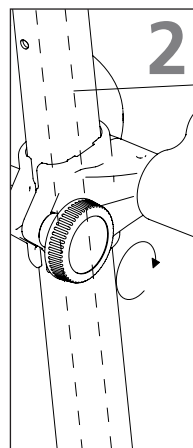

Vid rätt höjd vrids låsvredet medurs för att låsa positionen.

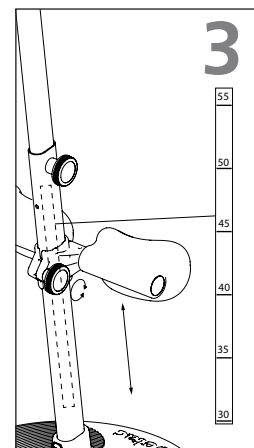

Benstöds höjd kan avläsas från skalan på stolpen. Numret ovanför benstödsfästet visar den aktuella höjden.



Kontrollera att låsvreden är ordentligt åtdragna. För löst åtdragna rattar kan orsaka att handtag eller knästöd glider ner och gör Turner osäker att använda.

### Placering och justering



Placera den nya sittplatsen (stol, rullstol, toalett eller säng) i vinkel med den befintliga sittplatsen.

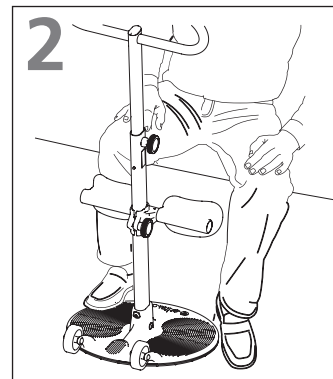

Placera Turner PRO in under brukarens fötter.

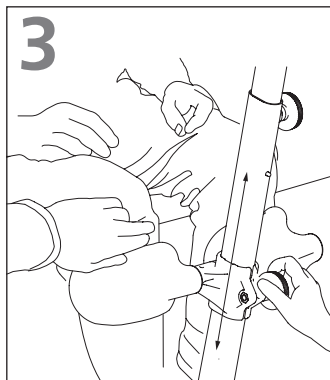

Justera höjden på benstödet så det är placerat två fingrar nedanför brukarens knäskål.

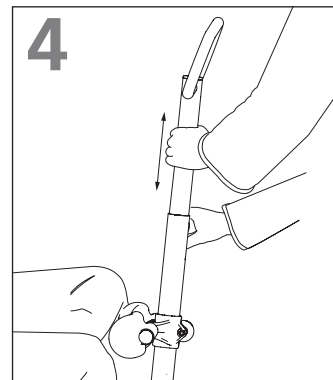

Justera höjden på handtaget till ett lägesom är funktionellt för både brukare och assistent.

## Transport och förvaring

Turner PRO kan förvaras och transporteras vid temperaturer mellan -25 - 70 ° C och relativ fuktighet mellan 15 - 93%

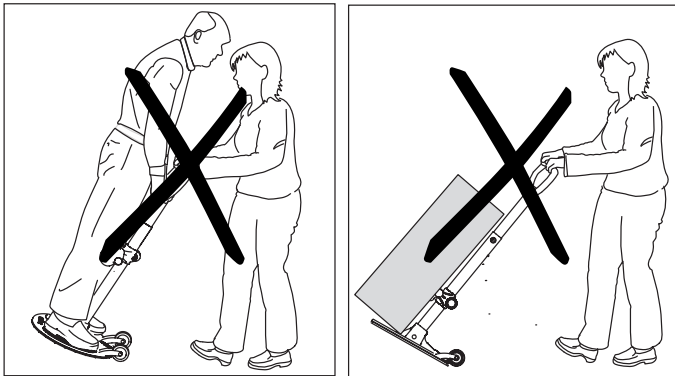

Använd inte Turner PRO för transport av personer eller gods.

## Förflyttning

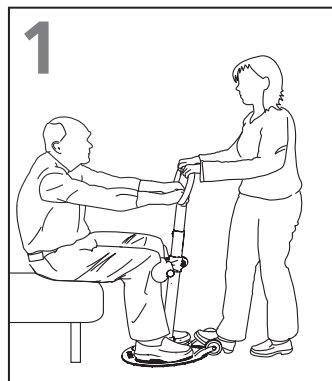

1  
Brukaren greppar handtaget, om möjligt med båda händerna. Assistenten greppar handtaget med båda händerna och placerar en fot på bottenplattans pedal.

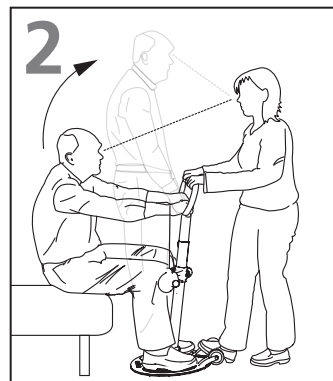

2  
Brukaren reser sig upp samtidigt som assistenten ger motvikt (tyngd på foten/ pedalen och genom att luta sig något bakåt).

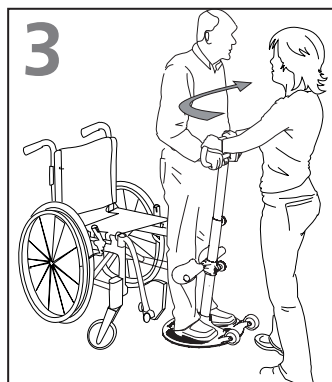

3  
Vrid Turner PRO så att brukaren kommer i position för den nya sittplatsen.



4  
Assistenten ger motvikt, (tyngd på foten/ pedalen och genom att luta sig något bakåt).  
Brukaren sätter sig ned  
Ha ögonkontakt med brukaren under hela förflyttningen.

## Brukare/ Assistent

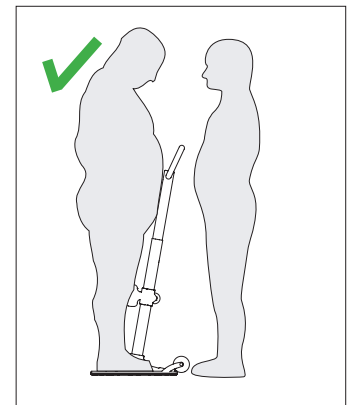
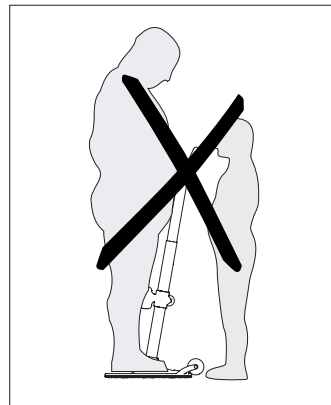

Assistenten måste kunna hantera brukarens vikt.

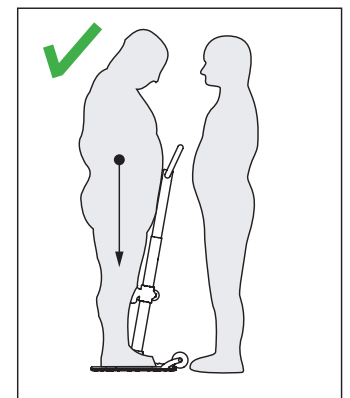
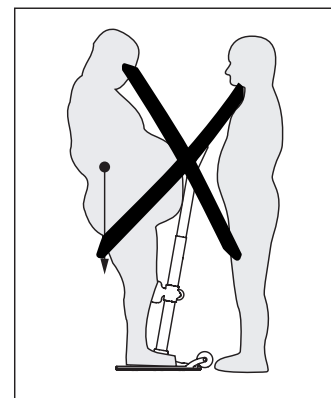

Se till att brukarens vikt är inom understödsytan för Turner PRO.

## Rengöring och desinficering

Rengör regelbundet. Torka med en fuktig trasa. Använd ett lämpligt pH-neutralt rengöringsmedel. Använd inte lösningsmedel eller starka vätskor, det kan skada ytorna på Turner. Vid behov av desinficering använd isopropylalkohol eller liknande. Undvik frätande rengöringsmedel. Ta bort hår och damm från hjulen och kontrollera att hjulen kan rotera fritt.



Se till att inte skada eller ta bort etiketter vid rengöring.

## Rekonditionering

Följ rengörings- och monteringsproceduren. Separat rekonditioneringsdokument finns på Etac.com.

## Återvinning

Separat dokument för återvinning finns att ladda ned på [www.etac.com](http://www.etac.com)

## Reservdelar

Separat dokument för reservdelar finns att ladda ned på [www.etac.com](http://www.etac.com)

## General



### Samsvarserklæring

Produktet og tilhørende tilbehør, som er beskrevet i denne bruksanvisningen, er i samsvar med forordning (EU) 2017/745 av 5. april 2017 - som medisinsk utstyr, risikoklasse I.

Produktet er produsert og testet i samsvar med EN 12182:2012 og utvalgte deler av EN/ISO 10535:2006.

Alle alvorlige hendelser som oppstår i forbindelse med enheten, skal rapporteres til produsenten og kompetent myndighet i landet der brukeren og/eller pasienten befinner seg.

### Bruksbetingelser:

Forflytning av en person kan være et risikoelement. Utstyret som omtales i denne bruksanvisningen skal kun brukes av kvalifisert personale.

### Garantimelding

To (2) års produktgaranti mot feil i materialer og arbeidsutførelse.

Les vilkår og betingelser på [www.etac.com](http://www.etac.com).

Gå til [www.etac.com](http://www.etac.com) for å laste ned nyeste versjon av vår dokumentasjon.

## Viktig

Denne bruksanvisningen inneholder viktige sikkerhetsinstruksjoner og informasjon om bruk av Turner PRO og tilbehør. Brukeren i denne bruksanvisningen er personen som forflyttes.

Assistenten er personen som betjener Turner PRO.



Dette symbolet indikerer viktig informasjon om sikkerhet. Disse instruksjonene må følges nøye.



Les bruksanvisningen før bruk!  
Det er viktig å forstå bruksanvisningens innhold fullt og helt før utstyret betjenes.

### Endringer og bruk av komponenter som er laget av andre produsenter:

Vi anbefaler at det kun brukes komponenter og reservedeler fra Etac. Samsvarserklæringen blir ugyldig, og Etac står ikke ansvarlig for garantien dersom utstyret er utsatt for modifikasjoner. Etac har intet ansvar for eventuelle feil eller ulykker som kan oppstå ved bruk av komponenter som er laget av andre produsenter.

## Risikovurdering

Vurder risikoen og ta notater.

Som assistent er du ansvarlig for brukerens sikkerhet!



Reparasjoner skal kun utføres av teknisk personell.

## Etiketter og symboler

### Produktetikett:

Etiketten inneholder art. nummer og serienummer (strekoder). EAN-koden inneholder

(01) (EAN no.): xxxxxxxxxxxxxx

(11) (Parti): ÅÅMMDD

(21) (Serinummer): xxxxx



### Symboler:

Detaljert forklaring av symboler på produktet:



Produsent



Produksjonsdato



Katalognummer



Serinummer



Medisinsk utstyr



CE-merket



Se bruksanvisningen



Maks. vasketemperatur



Maks. brukervekt (SWL)



ph ved vasking



QR-kode

### Kort brukerveiledning:

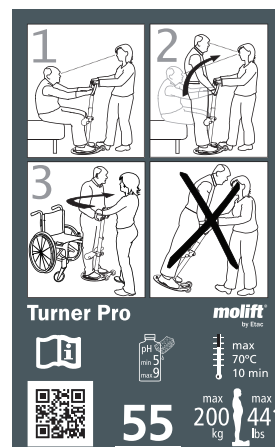

## Turner PRO - tiltenkt bruk

Turner Pro er et oppreisings- og forflytningshjelpemiddel som gjør det enklere for en pleier å hjelpe en bruker å reise seg og forflytte ham/henne til en annen sittestilling. Brukes av brukere som kan gripe og trekke opp sin egen kroppsvekt, men som likevel trenger støtte/hjelp til å reise seg opp og forflyttes. Formålet er forflytning av en person fra/til en seng, stol, rullestol, toalett eller lignende. Turner PRO er laget av lette materialer, og kan enkelt flytte til nye steder. Turner Pro skal kun brukes innendørs og på flatt underlag.

## Turner PRO

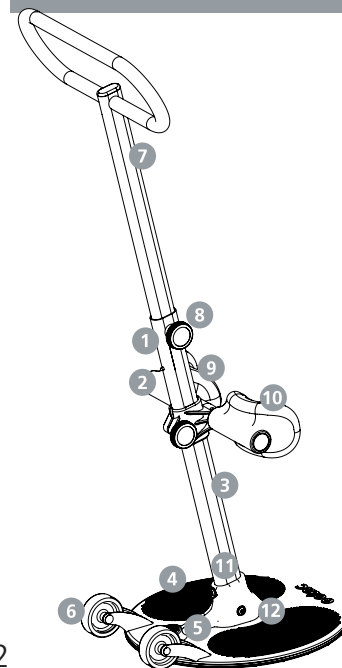

1. Ytre stang
2. Låsepinne
3. Høydenivåmerke
4. Fotplate
5. Assistentens fotstøtte
6. Transporthjul
7. Indre stang med håndtak
8. Dreieknott
9. Kort brukerveiledning
10. Benstøtte
11. Produktetikett
12. Bolter

## Tekniske data

## Maks brukervekt:

200 kg (441 lbs)

## Enhetsvekt:

8kg

## Dimensjoner:

Høyde (A): 0,8-1,2 m

Høyde (B): 0,3-0,55 m

Dybde (C): 0,46 m

Bredde (D): 0,45 m

Fotplate (Ø): 0,40 m

## Materiale:

Pulverlakkert aluminium, plast, stål.

## Forventet levetid:

Turner PRO har en forventet levetid på 5 år eller 15 000 vendesykluser.

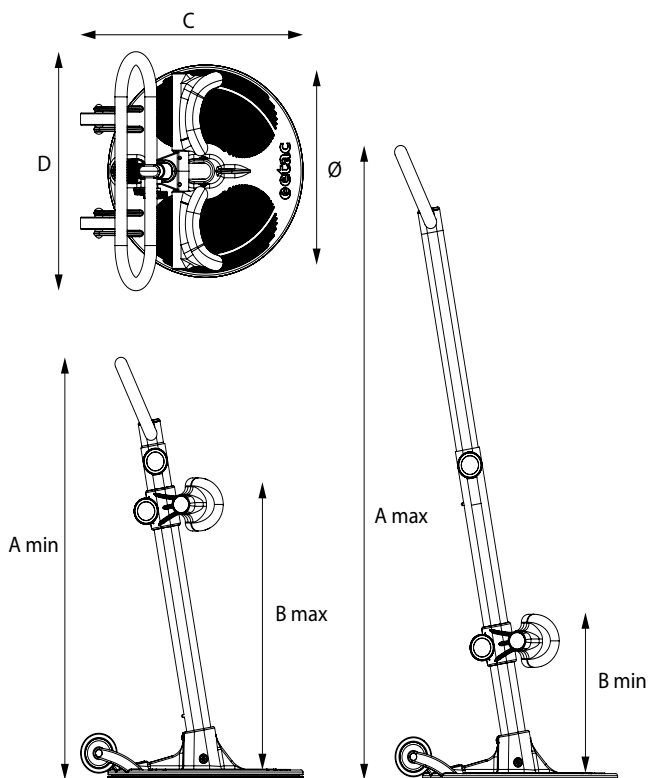

## Medfølgende deler

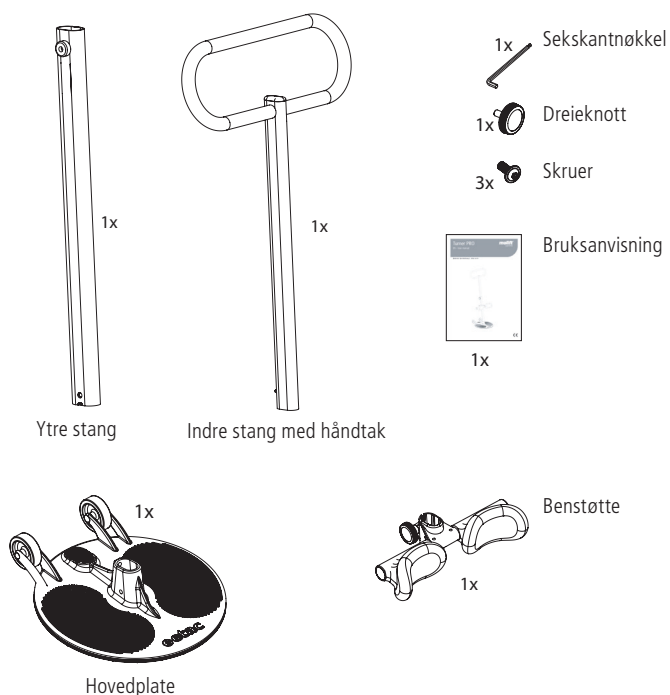

## Montering av benstøtte

Kneputene kan justeres individuelt. Benstøtten kan justeres trinnløst fra 0,3 til 0,55 meter. Følg disse tre trinnene når benstøtten monteres:

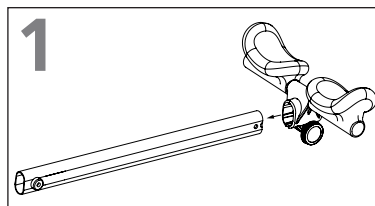

1  
Legg stangen ned på et jevnt underlag. Sett inn benstøtten med kneputene vendt oppover. Sørg for at begge knottene er på samme side

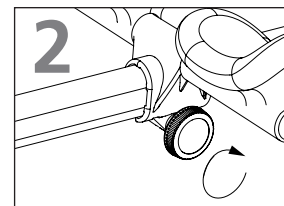

2  
Trekk til knotten ved å vri den med klokka.

## Montering av stang til fotplate

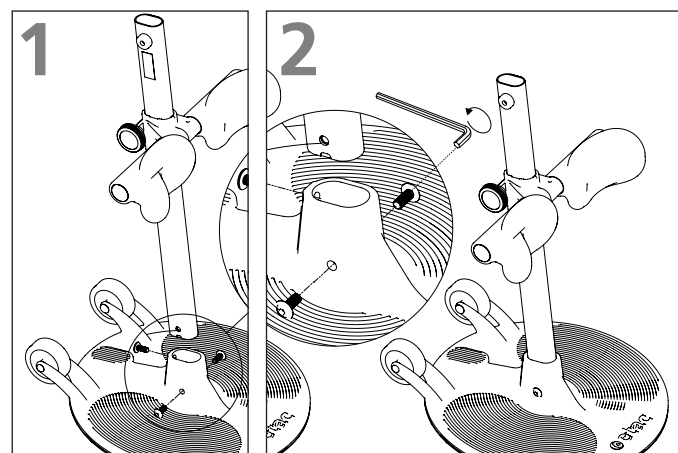

1  
Plasser fotplate på et jevnt underlag. Sett inn stangen i fotplaten. Bruk sekskantnøkkelen til å skru med kneputene vendt bort inn boltene. Trekk boltene godt til fra hjulene



Sørg for at alle de tre skruene er festet ordentlig. Løse bolter kan gjøre at stangen blir ustabil og gjøre Turner PRO utrygg.

## Montering av håndtak

Håndtaket kan justeres trinnløst fra 0,8 til 1,2 meter. Følg disse tre trinnene når håndtaket monteres:

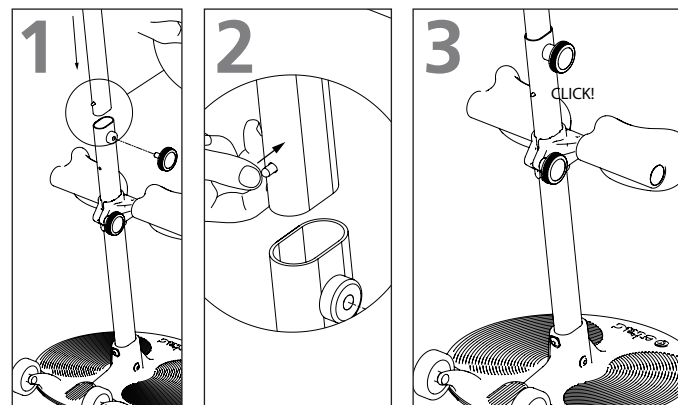

1  
Plasser håndtaket med låsepinnen med låsepinnen mot hjulene.

2  
Trykk inn låsepinnen og la håndtaket gli inn i den ytre stangen

3  
Ved riktig montering høres en klikkelyd. Vri og trekk til knotten.

### Sjekkliste etter montering



Turner PRO må ikke betjenes før monteringen er kontrollert i henhold til sjekklisten.

Bruk denne sjekklisten før Turner PRO tas i bruk, for å kontrollere at løfteren er riktig montert og at den kan betjenes trygt og riktig. Du finner flere detaljer i monteringsinformasjonen på forrige side. mer informasjon.

- Kontroller at benstøtten er montert på riktig måte
- Kontroller at de tre boltene mellom den ytre stangen og grunnplaten er montert på riktig måte og ordentlig trukket til.
- Kontroller at håndtaket (indre stang) er montert på riktig måte.
- Kontroller at Turner roterer fritt.

### Justering av høyde på håndtak

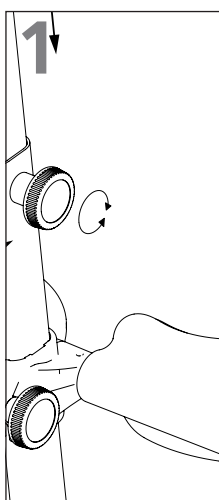

Vri knotten moturs for å justere høyden på håndtaket.

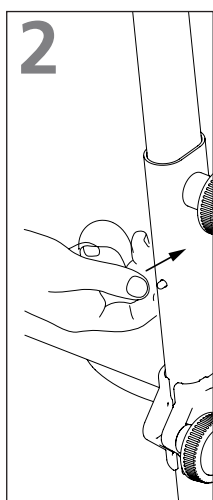

Trykk inn låsepinnen hvis håndtaket er i øvre posisjon.

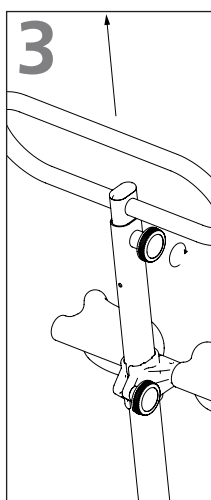

Når håndtaket står i riktig høyde, vrir du knotten medurs for å låse posisjonen.



Vær forsiktig med håndtaket når høyden skal justeres. Håndtaket kan skli ned og treffe brukers hode eller overkropp.



Håndtaket må ikke brukes i en posisjon som er høyere enn låsepinnens posisjon. Dette gjør at stangen blir ustabil og gjør Turner utrygg.

### Justering av høyde på benstøtte

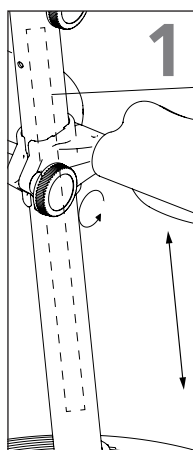

Vri knotten mot klokka og juster høyden på knestøtten

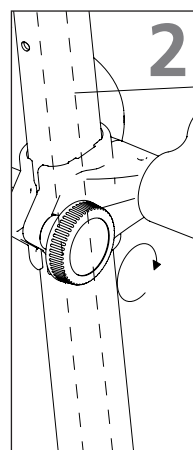

Når knestøtten står i riktig høyde, vrir du knotten medurs for å låse posisjonen.

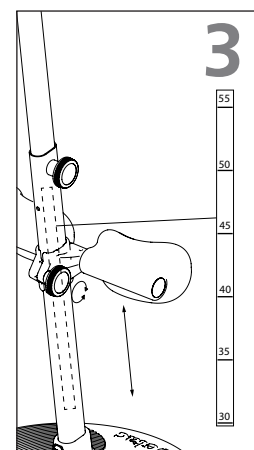

Høyden på knestøtten kan leses fra målestokken på stangen. Nummeret over benstøttebraketten henviser til korrekt høyde.



Kontroller at knottene er trukket ordentlig til. Løse knotter kan føre til at håndtak eller knestøtte glir ned og gjør Turner utrygg.

### Posisjonering av Turner PRO



Posisjoner det nye setet (stol, rullestol, toalett eller seng) i en 90 graders vinkel i forhold til det eksisterende sete.

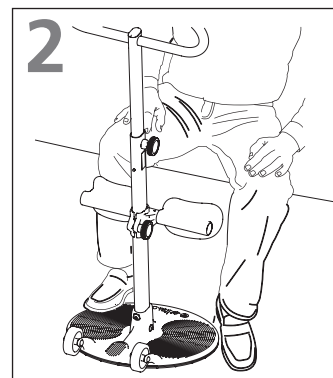

Posisjoner Turner PRO inn under brukerens føtter.

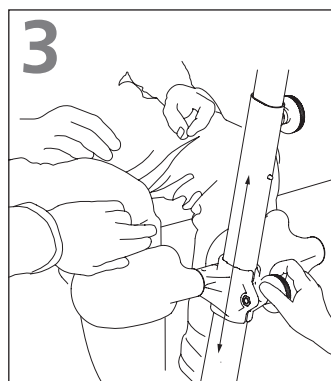

Juster høyden på benstøtten slik at den er posisjonert to fingerlengders avstand under brukerens kneskål.

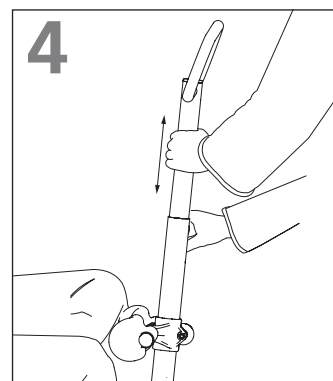

Juster høyden på håndtaket til en stilling som er behagelig for både bruker og assistent.

## Transport og lagring

Turner PRO kan lagres og transporteres ved temperaturer mellom -25 - 70 °C og relativ fuktighet mellom 15 - 93 %

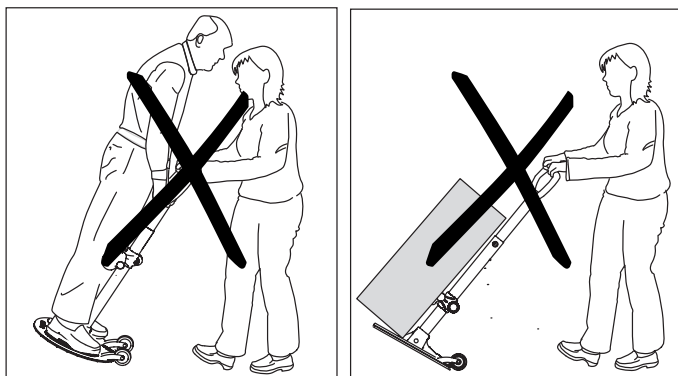

Turner PRO må ikke brukes til transport av mennesker eller varer..

## Forflytting av bruker

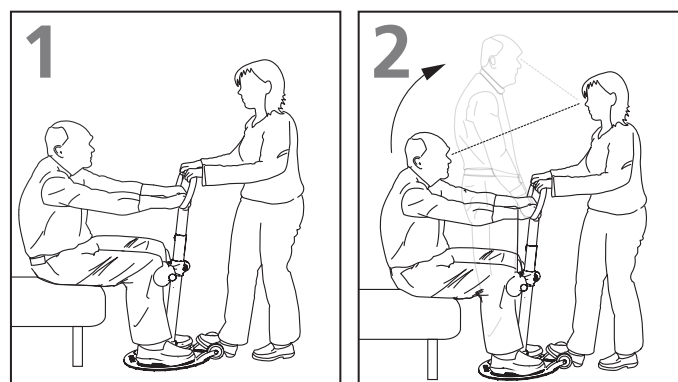

1 Grip håndtaket med begge hender og sett én fot på fotstøtten. Brukeren griper håndtaket, om mulig med begge hender.

2 Be brukeren å reise seg opp, samtidig som du skaper en motvekt til brukerens vekt med en fot og begge hender (bruk kroppsvekten med å lene deg bakover).

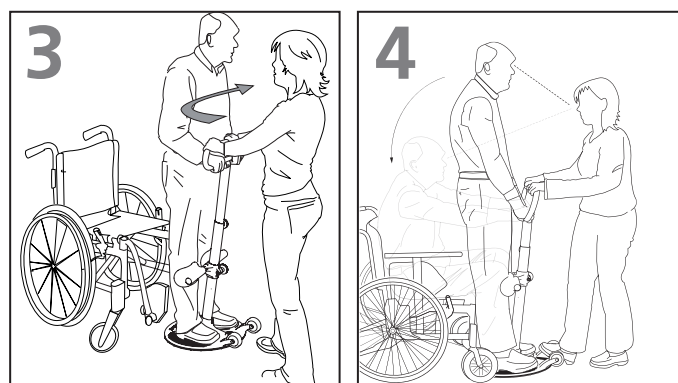

3 Vri Turner PRO slik at brukeren forflyttes til fremsiden av det nye setet.

4 Tråkk på fotstøtten, bruk vekten din til å holde imot, og be brukeren sette seg ned. Hold øyekontakt med brukeren under hele forflytningsprosessen.

## Bruker / assistent

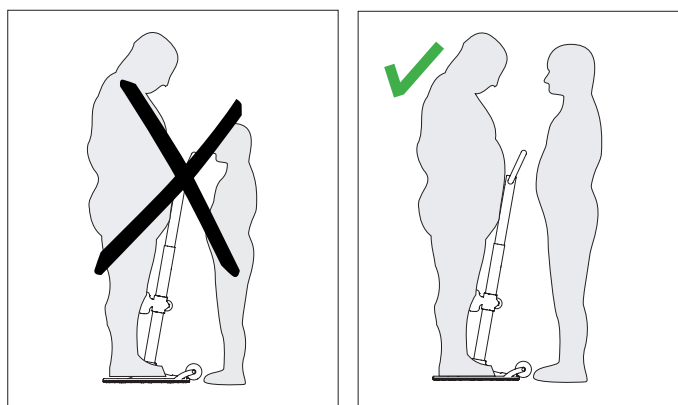

Assistenten må kunne håndtere brukerens vekt.

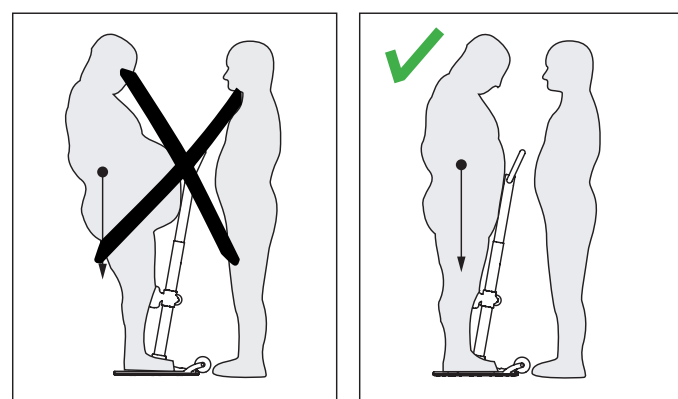

Kontroller at brukerens tyngdepunkt er innenfor grunnplaten..

## Rengjøring og desinfeksjon

Vaskes regelmessig. Rengjør overflater med en fuktig klut og et egnet pH-nøytralt rengjøringsmiddel. Ikke bruk løsemidler eller sterke væsker. Det kan skade overflatene på Turner-hjelpemiddelet. Ved nødvendig desinfeksjon: Bruk isopropylalkohol eller lignende. Unngå slipende rengjøringsprodukter. Fjern hår og lo fra hjulene, og kontroller at hjulene roterer fritt.



Pass på at etikettene ikke blir skadet eller løsner under rengjøring.

## Rekondisjonering

Følg prosedyren for rengjøring og montering. Et eget rekondisjoneringsdokument er tilgjengelig på Etac.com.

## Gjenvinning

Turner PRO kan kastes som metallavfall. Instruksjoner for gjenvinning er tilgjengelig på Etac.com

## Reservedeler

En liste med reservedeler er tilgjengelig på Etac.com.

## Generel

	<p><b>CE-erklæring</b></p> <p>Produktet og det relaterede tilbehør, der er beskrevet i denne brugervejledning, er i overensstemmelse med forordning (EU) 2017/745 af 5. april 2017 - som medicinsk udstyr, risikoklasse I. Produktet er fremstillet og testet i henhold til EN 12182:2012 og udvalgte dele af EN/ISO 10535:2006.</p> <p>Alle alvorlige hændelser, der opstår i forbindelse med udstyret, skal indberettes til producenten og den kompetente myndighed i brugerens og/eller patientens medlemsstat.</p>
---	--

### Betingelser for anvendelse:

Der er altid en vis risiko ved forflytning af en person. Det udstyr, der er beskrevet i denne brugervejledning, må kun anvendes af uddannet personale.

### Garanti

To års garanti på fabrikations- og materialefejl på vores produkter. Se [www.etac.com](http://www.etac.com) for vilkår og betingelser. Besøg [www.etac.com](http://www.etac.com) for at downloade den nyeste version af vores dokumentation.

## Vigtigt

Denne brugervejledning indeholder vigtige sikkerhedsinstruktioner og oplysninger vedrørende anvendelse af Turner PRO og tilbehøret. I vejledningen er brugeren den person, der bliver forflyttet. Hjælperen er den person, der betjener Turner PRO.



Dette symbol angiver vigtige oplysninger angående sikkerhed. Følg disse instruktioner nøje.



Læs brugervejledningen inden brug!  
Det er vigtigt, at du fuldt ud forstår indholdet i brugervejledningen, før du forsøger at bruge udstyret.

### Endringer og bruk av komponenter som er laget av andre produsenter:

Vi anbefaler, at der udelukkende anvendes Etac-komponenter og -reservedele. Overensstemmelseserklæringen vil ikke længere være gyldig, og Etacs garantiforpligtelse bortfalder, hvis der foretages nogen form for modifikationer på produktet. Etac er ikke ansvarlig for fejl eller uheld, som måtte opstå ved brug af komponenter fra andre producenter.

## Risikovurdering

Vurdér risikoen, og tag notater

Som hjælper er du ansvarlig for brugerens sikkerhed!



Reparationer må kun udføres af teknisk personale.

## Mærkatet og symboler

### Produktmærkat:

Mærkatet viser varenr. og serienr. (stregkoder). EAN-koden indeholder:

(01) (EAN no.): xxxxxxxxxxxxxx

(11) (Batch): ÅÅMMDD

(21) (Serienummer): xxxxx



### Symboler:

Symboler, som bruges i produktet, beskrives her nærmere:



Producent



Fremstillingsdato



Katalognummer



Løbenummer



Medicinsk udstyr



CE marked



Refer to user manual



Maks. temperatur ved vask



Maks. brugervægt (sikker arbejdsbelastning)



pH ved vask



QR-kode

### Kort brugervejledning:

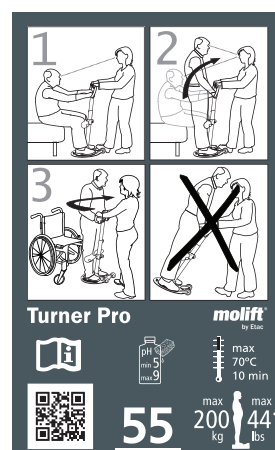

## Turner PRO – tilsigtet anvendelse

Turner PRO er et hjælpemiddel til anvendelse ved forflytning fra siddende til stående stilling, der gør det nemmere for hjælperen at assistere en bruger med at komme op at stå og med at forflytte vedkommende til en anden siddende stilling. Produktet kan anvendes af brugere, som er i stand til at gribe og trække deres egen kropsvægt op, men har brug for støtte/hjælp til at rejse sig op og flytte sig. Formålet er at forflytte en person til/fra seng, stol, kørestol, toilet eller lignende. Turner PRO er fremstillet af letvægtsmaterialer og kan nemt flyttes til nye steder. Turner PRO må kun anvendes indendørs og på et plant underlag.

## Turner PRO

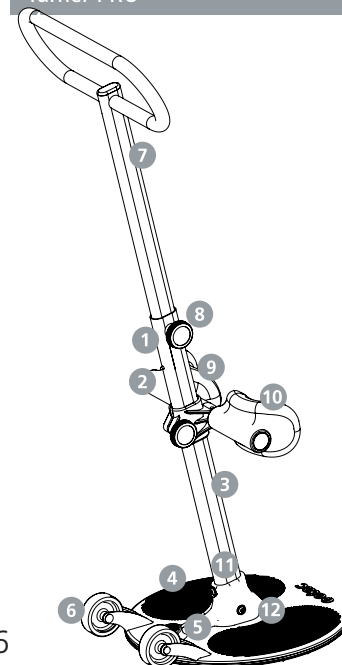

1. Udvendig stang
2. Låsestift
3. Højdemærkat
4. Bundplade
5. Hjælperens fodstøtte
6. Transporthjul
7. Indvendig stang med håndtag
8. Låsegreb
9. Kort brugervejledning
10. Benstøtte
11. Produktmærkat
12. Bolte



## Tekniske data

## Sikker arbejdsbelastning

200 kg (441 lbs)

## Enhedens vægt:

8kg

## Mål:

Højde (A): 0,8-1,2 m  
 Højde (B): 0,3-0,55 m  
 Dybde (C): 0,46 m  
 Bredde (D): 0,45 m  
 Fodplade (Ø): 0,40 m

## Materiale:

Pulverlakeret aluminium, plast, stål.

## Forventet levetid:

Turner PRO har en forventet levetid på fem år eller 15.000 drejecykler.

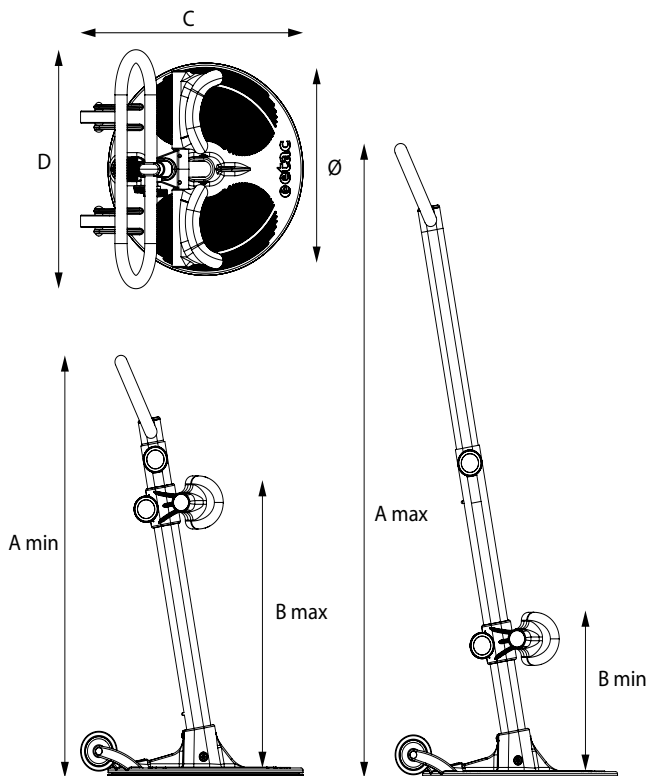

## Leverede dele

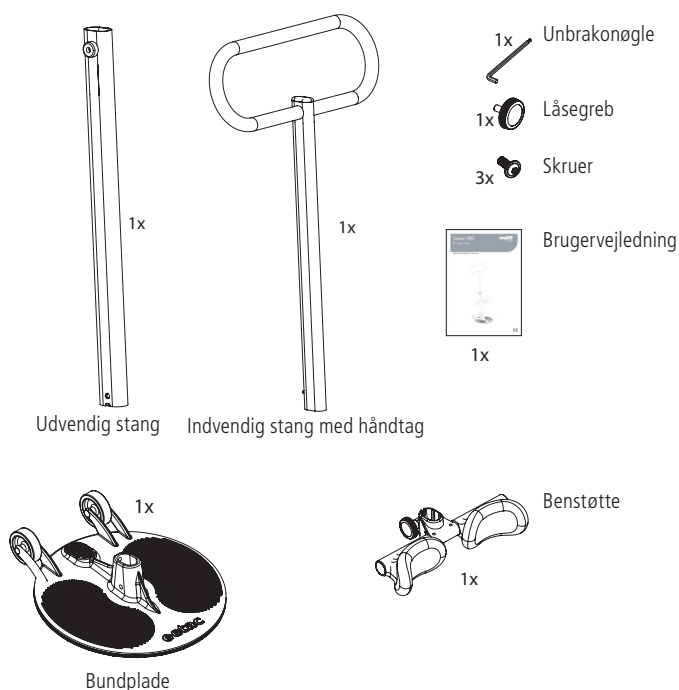

## Montering af benstøtte

Knæpuderne er individuelt justerbare. Benstøtten er trinløst justerbar fra 0,30 til 0,55 meter. Følg disse tre trin, når benstøtten monteres:

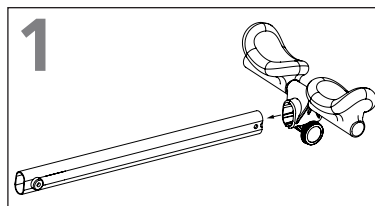

Læg stangen ned på en jævn overflade. Isæt benstøtten med knæpuderne pegende opad. Sørg for, at begge låsegreb er på samme side.

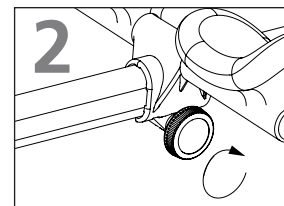

Spænd låsegrebet ved at dreje grebet med uret.

## Montering af stang på bundplade

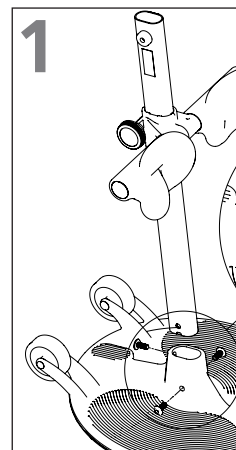

Anbring bundpladen på en jævn overflade. Isæt stangen med knæpuderne pegende væk fra hjulene.

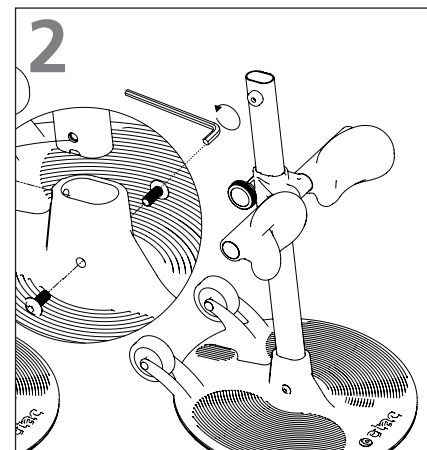

Isæt alle tre skruer i hullerne i bundpladen. Brug unbrakonøglen til at skrue boltene i. Stram boltene godt.



Sørg for, at alle tre bolte er korrekt fastgjort. Løse bolte kan gøre stangen ustabil, så Turner PRO ikke længere er sikker at bruge.

## Montering af håndtag

Håndtaget er trinløst justerbart fra 0,80 til 1,2 meter.

Følg disse tre trin, når håndtaget monteres:

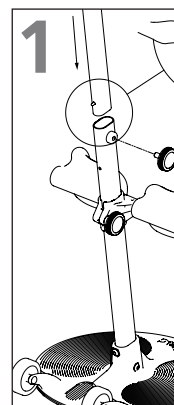

Anbring håndtaget med låsestiften pegende mod hjulene.

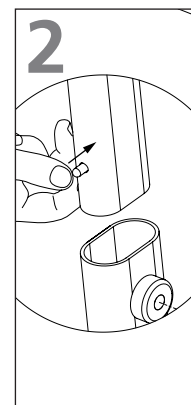

Pres låsestiften ind, og før stangen ind i den monterede stang.

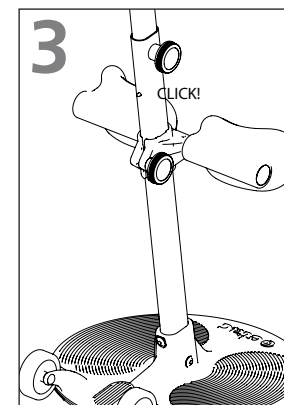

Den er korrekt monteret, når der lyder et klik. Drej låsegrebet, og spænd det.

## Tjekliste efter samling



Når du har samlet Turner PRO, må du ikke begynde at anvende den, før du har afsluttet kontrollen i henhold til tjeklisten.

Brug denne tjekliste til at bekræfte, at Turner PRO er korrekt samlet og kan betjenes korrekt og sikkert, før den tages i brug. Se samlingsoplysningerne på foregående side for at få flere oplysninger. forrige side. mer information.

- Sørg for, at benstøtten er monteret korrekt.
- Sørg for, at alle tre bolte mellem den udvendige stang og bundpladen er monteret korrekt og spændt godt til.
- Sørg for, at håndtaget (den indvendige stang) er monteret korrekt.
- Sørg for, at Turner PRO roterer frit..

## Justering af håndtagets højde

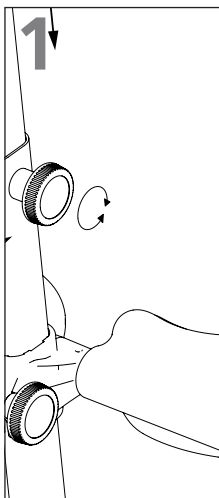

Drej låsegrebet mod uret, og juster håndtagets højde.

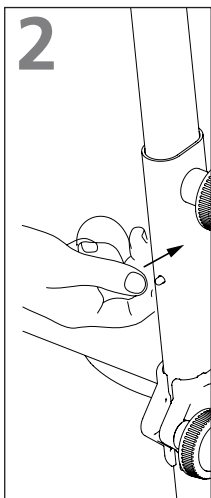

Skub låsestiften ind, hvis håndtaget er i øverste position.

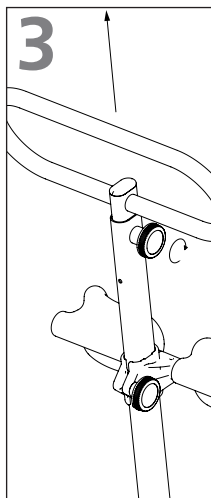

Når den korrekte håndtagshøjde er opnået, drejes låsegrebet med uret for at låse positionen.



Vær opmærksom på håndtaget, når højden justeres. Håndtaget kan glide ned og ramme operatøren i hovedet eller på overkroppen.



Undlad at bruge håndtaget, når det befinder sig i en position over låsestiftens position. Det gør stangen ustabil, så Turner PRO ikke længere er sikker at bruge.

## Justering af benstøttens højde

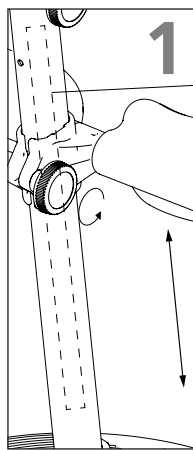

Drej låsegrebet med uret, og juster knæstøttens højde.

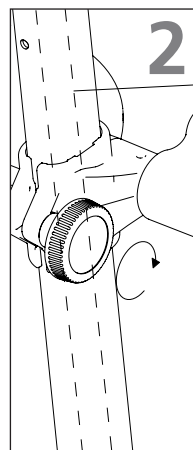

Når den korrekte knæstøtkehøjde er opnået, drejes låsegrebet med uret for at låse positionen.

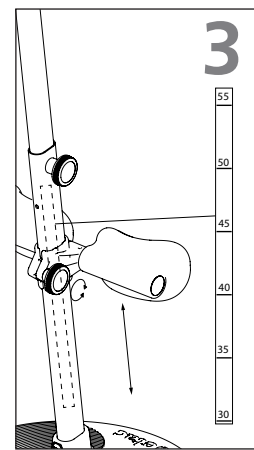

Knæstøtkehøjden kan aflæses på højdemærkat på stangen. Tallet over benstøttebeslaget refererer til den korrekte højde.



Sørg for, at låsegrebene er sikkert tilspændt. Løse låsegreb kan resultere i, at håndtag eller knæstøtte glider ned, så Turner PRO ikke længere er sikker at bruge

## Placering af Turner PRO



Placer det nye sæde (stol, kørestol, toilet eller seng) i en 90 graders vinkel i forhold til det eksisterende sæde

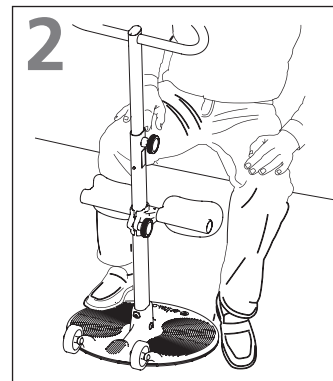

Før Turner PRO ind under brugerens fødder

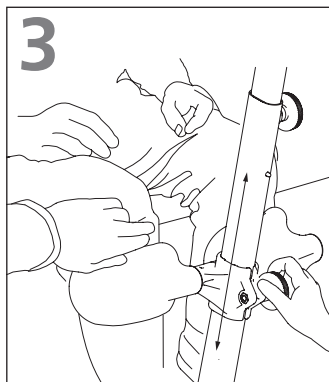

Juster højden på benstøtten, så den er placeret to fingerbredder under brugerens knæskal

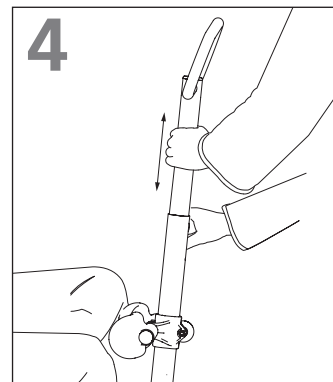

Juster højden på håndtaget til en position, der er behagelig for både bruger og hjælper.

## Transport og opbevaring

Turner PRO kan opbevares og transporteres ved temperaturer mellem -25 og 70 °C og ved en relativ luftfugtighed på mellem 15 og 93 %.

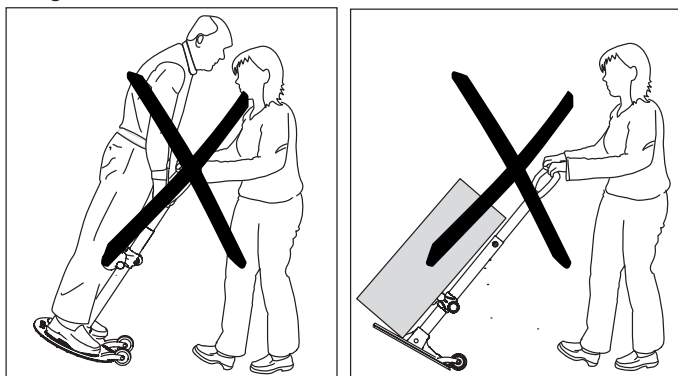

Turner PRO må ikke anvendes til transport af mennesker eller ting.

## Forflytning af brugeren

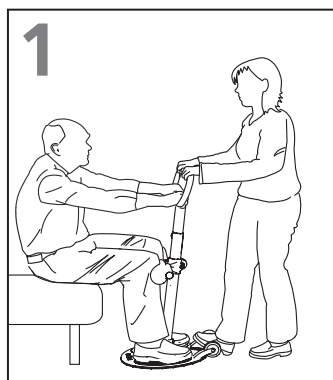

Grib fat i håndtaget med begge hænder, og sæt en fod på fodstøtten. Brugeren griber fat i håndtaget, om muligt med begge hænder.

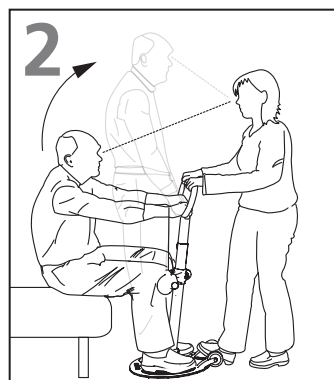

Derefter opfordrer du brugeren til at rejse sig, samtidig med at du afbalancerer brugerens vægt ved hjælp af en fod og dine hænder (brug din kropsvægt ved at læne dig bagover).

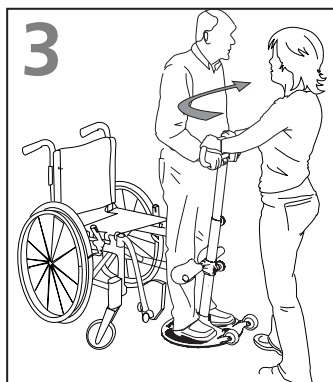

Drej Turner PRO, så brugeren forflyttes og står foran det nye sæde



Træd på fodstøtten, læn din vægt på den, og bed brugeren om at sætte sig ned. Oprethold øjenkontakt med brugeren under hele forflytningsprocessen.

## Bruger/hjælper

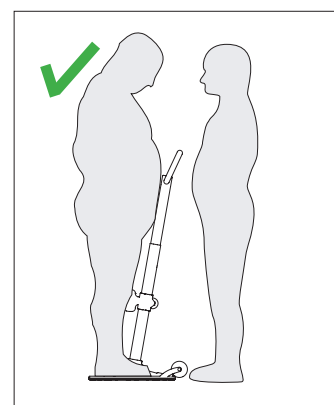
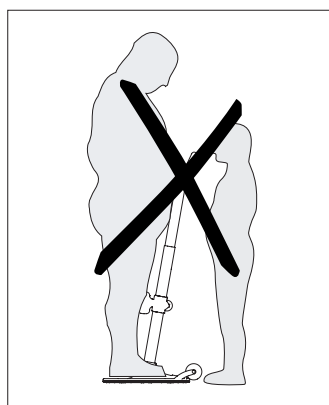

Hjælperen skal være i stand til at håndtere brugerens vægt.

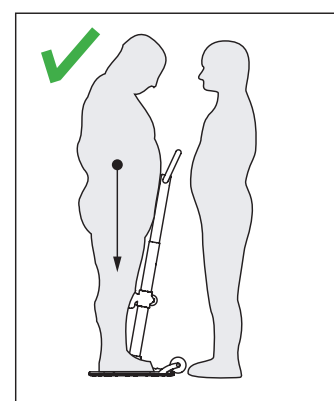
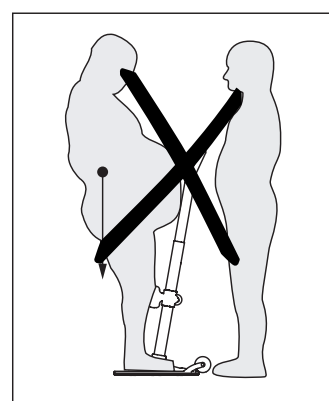

Sørg for, at brugerens vægt befinder sig inden for bundpladen.

## Rengøring og desinfektion

Rengør personløfteren regelmæssigt. Rengør overfladerne med en fugtig klud med et pH-neutralt rengøringsmiddel. Brug ikke opløsningsmidler eller stærke væsker, da det kan ødelægge overfladerne på Turner PRO. Til desinficering, når det er nødvendigt: Brug isopropylalkohol eller lignende midler. Undgå slibende rengøringsprodukter. Fjern hår og luv fra hjulene, og tjek, at hjulene roterer frit.



Kontrollér, at du ikke beskadiger eller fjerner mærkater under rengøringen

## Fornyelse

Følg proceduren for rengøring og samling. Separat fornyelsesdokument er tilgængeligt på Etac.com

## Genbrug

Turner PRO kan bortskaffes som metalaffald. Genbrugsinstruktioner er tilgængelige på Etac.com.

## Reserve dele

Reservepartsliste er tilgængelig på Etac.com.

**Yleinen**

	<p><b>CE-ilmoitus</b></p> <p>Tuote ja sen tässä käyttöohjeessa kuvatut lisävarusteet ovat 5.4.2017 annetun asetuksen (EU) 2017/745 mukaisia riskiluokkaan I kuuluvia lääkinnällisiä laitteita.</p> <p>Tuote on valmistettu ja testattu standardin EN 12182:2012 ja standardin EN/ISO 10535:2006 tiettyjen osien mukaisesti.</p> <p>Kaikista laitteeseen liittyvistä vakavista tapauksista on ilmoitettava valmistajalle ja sen jäsenvaltion toimivaltaiselle viranomaiselle, jossa käyttäjä ja/tai potilas sijaitsee.</p>
---	---

**Käyttöehdot:**

Henkilön siirtämiseen voi liittyä riski. Ainoastaan koulutettu henkilökunta saa käyttää tässä käyttöohjeessa kuvattuja laitteita.

**Takuu:**

Kahden vuoden takuu, joka korvaa työstä ja materiaaleista johtuvat viat tuotteissamme.

Tarkista takuehdot osoitteesta [www.etac.com](http://www.etac.com).

Lataa dokumentaatiomme usin versio osoitteesta [www.etac.com](http://www.etac.com)

**Tärkeää**

Dämä käyttöohje sisältää Turner PRO -laitteen ja lisävarusteiden käyttöön liittyviä tärkeitä turvallisuusohjeita ja tietoja.

Käyttöohjeessa käyttäjällä tarkoitetaan siirrettävää henkilöä.

Avustaja on Turner PRO -laitetta käyttävä henkilö.

	<p>Tämä merkki tarkoittaa tärkeitä turvallisuuteen liittyviä tietoja. Noudata näitä ohjeita huolellisesti.</p>
---	--

	<p>Lue käyttöohje ennen käyttöä! On tärkeää ymmärtää käyttöohjeen sisältö kokonaisuudessaan, ennen kuin yrittää käyttää laitetta.</p>
---	---

**Muutokset ja muiden valmistajien osien käyttäminen:**

Suosittellemme ainoastaan Etac-komponenttien ja -varaosien käyttämistä. Vaatimustenmukaisuusvakuutus ei ole voimassa eikä Etac vastaa takuusta, jos tuotteeseen tehdään muutoksia. Etac ei vastaa vioista ja tapaturmista, joita voi ilmetä käytettäessä muiden valmistajien komponentteja.

**Riskien arviointi**

Arvioi riski ja tee muistiinpanoja.

Avustajana vastaat käyttäjän turvallisuudesta!

	<p>Vain tekninen henkilökunta saa tehdä korjaustöitä.</p>
---	---

**Mærkater og symboler**

**Tuotteen tarra::**

Tarra sisältää tuote- ja sarjanumeron (viivakoodit). EAN-koodin sisältö

(01) (EAN nro.): xxxxxxxxxxxxxxx

(11) (Erä): VVKKPP

(21) (Numero di serie): xxxxx



**Symbolit:**

Tuotteessa käytettävät symbolit tarkemmin selitettynä:

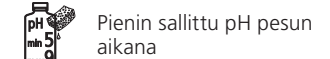
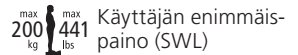
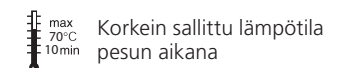
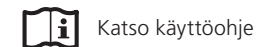
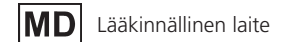

**Lyhyt käyttöohje:**

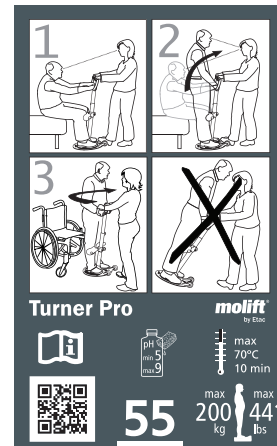

**Turner PRO - käyttötarkoitus**

Turner Pro on istuma-asennosta seisomaan nousemiseen ja siirtämiseen tarkoitettu apuväline, jonka avulla hoitaja voi helpommin auttaa käyttäjän seisomaan ja siirtää tämän erillaiseen istuma-asentoon. Tuote on tarkoitettu käyttäjille, jotka saavat otteen kahvasta ja pystyvät vetämään kehonsa painon ylös, mutta tarvitsevat kuitenkin tukea/apua seisomaan nousuun ja siirtymiseen. Laite on tarkoitettu henkilön siirtämiseen vuoteesta/vuoteeseen, tuolista/tuoliin, pyörätuolista/pyörätuoliin tai WC:stä/WC:hen. Turner PRO on valmistettu kevyistä materiaaleista, joten se on helppo siirtää uusiin paikkoihin. Sitä saa käyttää vain sisätiloissa, tasaisilla pinnoilla.

**Turner PRO**

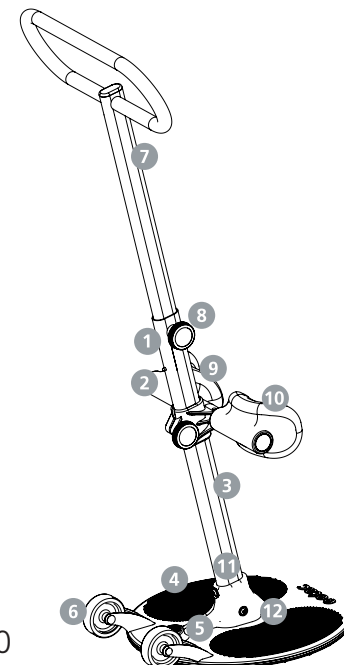

1. Ulompi pylväs
2. Sokka
3. Korkeustarra
4. Päälevy
5. Avustajan jalkalauta
6. Kuljetuspyörät
7. Sisempi pylväs kahvoineen
8. Kääntönoppi
9. Lyhyt käyttöohje
10. Jalkatuki
11. Tuotteen tarra
12. Pultit

## Tekniset tiedot

Suurin turvallinen kuorma (SWL, Safe Working Load):

200 kg (441 lbs)

Laitteen paino:

8kg

Mitat:

Korkeus (A): 0,8 - 1,2 m

Korkeus (B): 0,3 - 0,55 m

Syvyys (C): 0,46 m

Leveys (D): 0,45 m

Jalkalevy (Ø): 0,40 m

Materiaali:

Jauhemaalattu alumiini, muovi, teräs.

Arvioitu käyttöikä:

Turner PRO -laitteen arvioitu käyttöikä on 5 vuotta tai 15 000 kääntökertaa

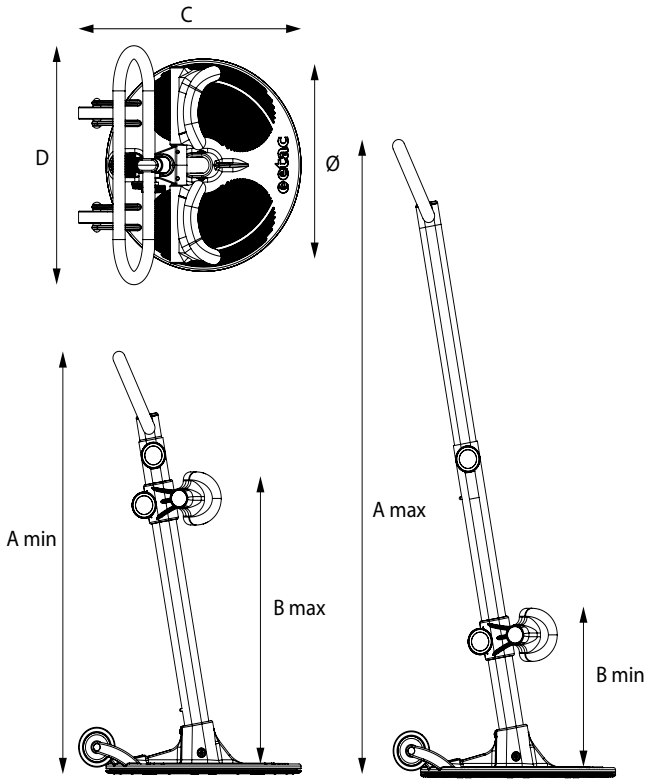

## Jalkatuen kiinnitys

Polvipehmusteet ovat säädettävissä yksilöllisesti. Jalkatuet ovat säädettävissä portaattomasti 0,3 - 0,55 metrin alueella. Noudata jalkatuen asennuksessa näitä kolmea ohjetta:

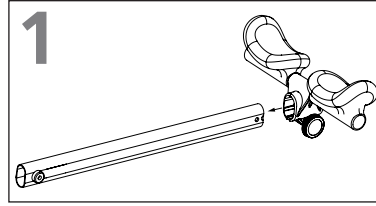

Laske pylväs alas tasaiselle pinnalle. Aseta jalkatuki siten, että polvipehmusteet ovat ylöspäin. Varmista, että molemmat nupit ovat samalla puolella.

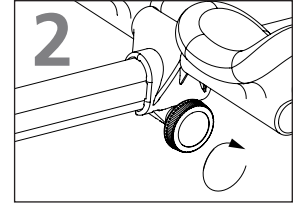

Kiristä nuppi kääntämällä myötäpäivään.

## Pylvään kiinnittäminen päälevyyn

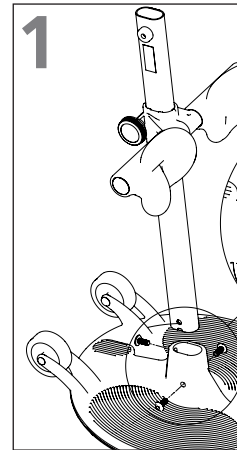

Aseta pohjalevy tasaiselle pinnalle. Aseta pylväs siten, että polvipehmusteet osoittavat poispäin pyöristä.

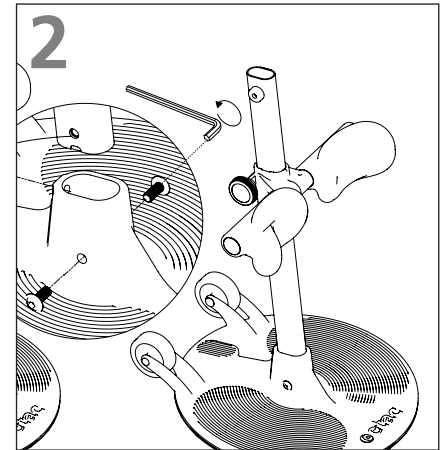

Aseta kaikki kolme ruuvia pohjalevyssä oleviin reikiin. Kierrä pultit kiinni kuusiokoloavaimella. Kiristä pultit tukevasti.



Varmista, että kaikki kolme pulttia on kiinnitetty hyvin. Löysät pultit voivat tehdä pylvästä huojuvan ja Turner PRO -laitteesta vaarallisen käytössä.

## Toimitetut osat

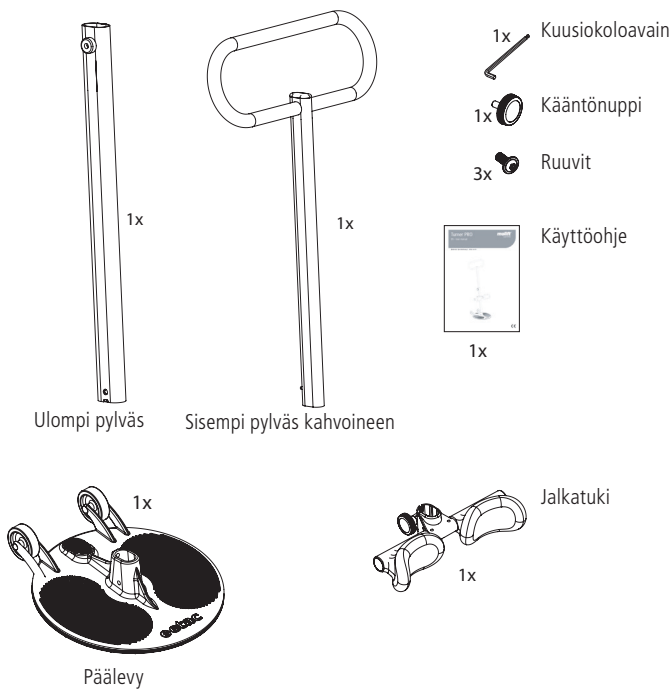

## Kahvan kiinnitys

Kahva on säädettävissä portaattomasti 0,8 - 1,2 metrin alueella. Noudata näitä kolmea ohjetta kahvan asennuksessa:

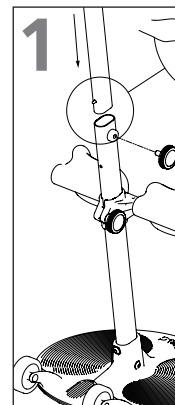

Aseta kahva siten, että sokka osoittaa pyöriin päin.

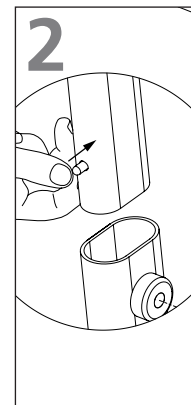

Paina sokka sisään ja aseta pylväs kiinnitetyn pylvään sisään.

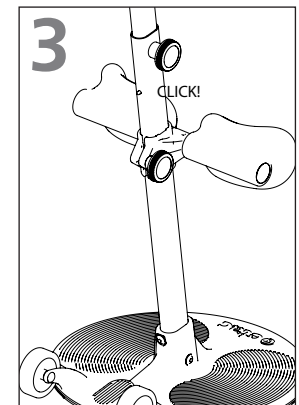

Kiinnitys on tehty oikein, kun kuuluu napsahdus. Käännä nuppiä ja kiristä se.

### Kokoamisen jälkeinen tarkistuslista



Älä aloita Turner PRO -laitteen käyttöä ennen kuin kokoamisen jälkeen käytettävän tarkistuslistan mukainen tarkastus on tehty.

Varmista ennen käyttöä tämän tarkistuslistan avulla, että Turner PRO on asennettu oikein ja toimii asianmukaisesti ja turvallisesti. Katso tarkempia tietoja edellisen sivun asennusohjeesta.

- Varmista, että jalkatuki on kiinnitetty oikein..
- Varmista, että kaikki ulomman pylvään ja päälevyn välillä olevat kolme pulttia on kiinnitetty oikein ja kiristetty kunnolla.
- Varmista, että kahva (sisempi pylväs) on kiinnitetty oikein.
- Varmista, että Turner pääsee pyörimään vapaasti.

### Kahvan korkeuden säätäminen

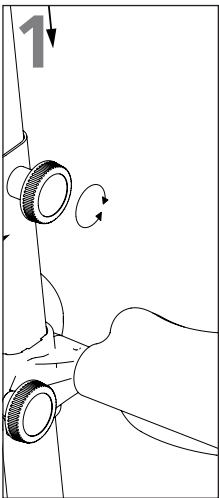

Käännä nuppia vastapäivään ja säädä kahvan korkeus.

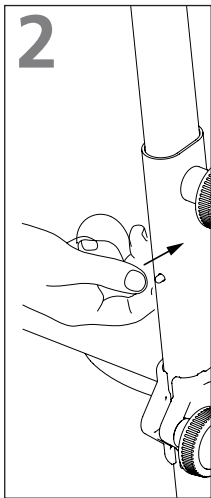

Työnnä sokka sisään, jos kahva on yläasennossa.

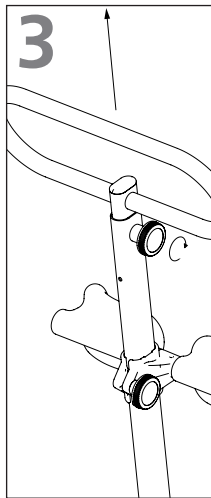

Kun kahva on sopivalla korkeudella, lukitse se siihen kääntämällä nuppia myötäpäivään.



Varo kahvaa korkeutta säätäessäsi. Kahva voi liukua alas ja osua käyttäjän päähän tai ylävartaloon.



Älä käytä kahvaa sokan asennon yläpuolella. Silloin pylväästä voi tulla huojuva ja Turnerista vaarallinen käytössä.

### Jalkatuen korkeuden säätäminen

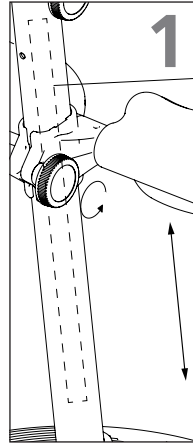

Käännä nuppia vastapäivään ja säädä polvituen korkeus.

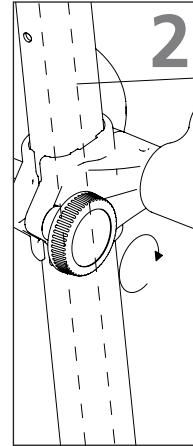

Kun polvituki on sopivalla korkeudella, lukitse se siihen kääntämällä nuppia myötäpäivään.

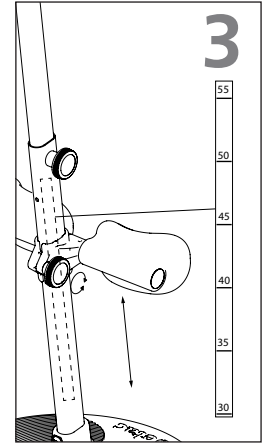

Polvituen korkeuden voi tarkistaa pylvään asteikosta. Jalkatuen kiinnikkeen yläpuolella näkyvä numero kertoo oikean korkeuden.



Varmista, että nupit on kiristetty kunnolla. Jos nupit jäävät löysälle, kahva tai polvituki voi liukua alas ja tehdä Turnerista vaarallisen käytössä.

### Turner PRO -laitteen asettaminen



Aseta uusi istuin (tuoli, pyörätuoli, WC tai vuode) samaan asentoon nykyisen istuimen suhteen.

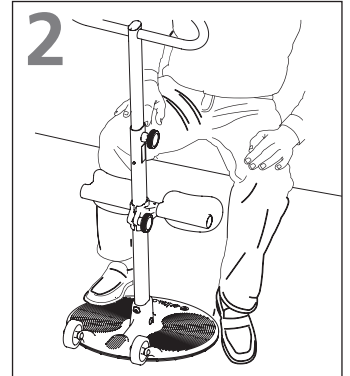

Työnnä Turner Pro käyttäjän jalkojen alle.

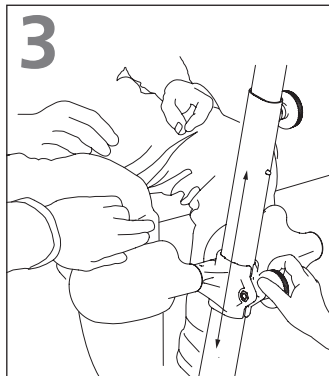

Säädä jalkatuen korkeus siten, että se on kahden sormen verran käyttäjän polvilumpion alapuolella.

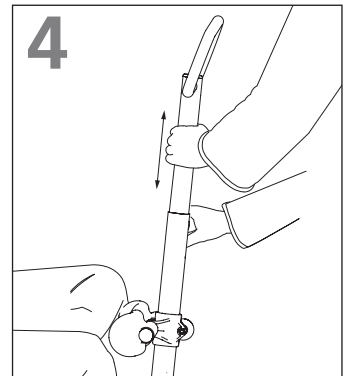

Säädä kahvan korkeus kohtaan, joka on mukava sekä käyttäjälle että avustajalle.

## Kuljetus ja säilytys

Turner PRO -laitetta voi säilyttää ja kuljettaa -25 - 70 °C:n lämpötiloissa, suhteellisen kosteuden ollessa 15 - 93 %.

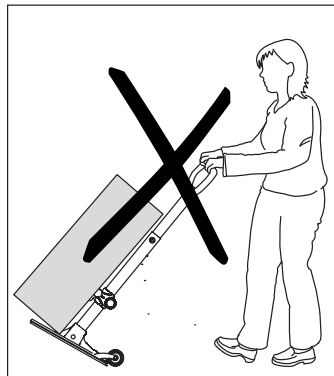

Älä käytä Turner Pro -laitetta ihmisten tai tavaroiden kuljettamiseen.

## Käyttäjän siirtäminen

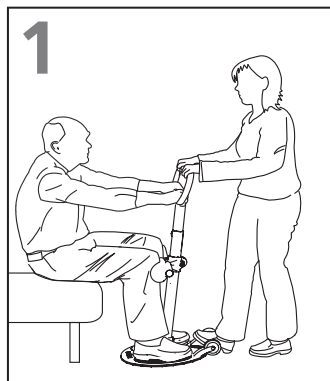

1 Tartu kahvaan molemmin käsin ja aseta toinen jalka jalkatuen päälle. Käyttäjä tarttuu kahvaan mieluiten molemmin käsin.

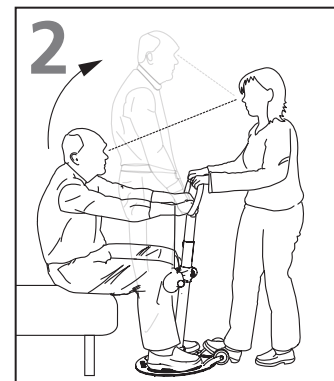

2 Kannusta käyttäjää nousemaan seisomaan ja toimi samaan aikaan vastapainona käyttäjän painolle jalan ja käsien avulla (käytä kehosi painoa nojaamalla taaksepäin).

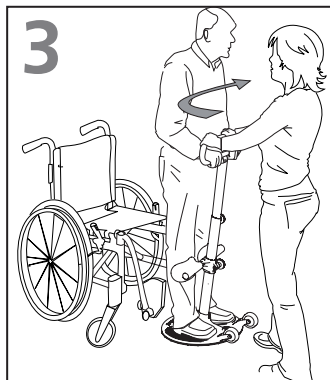

3 Käännä Turner PRO siten, että käyttäjä pääsee uuden istuimen etupuolelle.



4 Astu jalkatuen päälle, tue painoasi ja pyydä käyttäjää istuutumaan. Säilytä katsekontakti käyttäjään koko siirtoprosessin ajan.

## Käyttäjä/avustaja

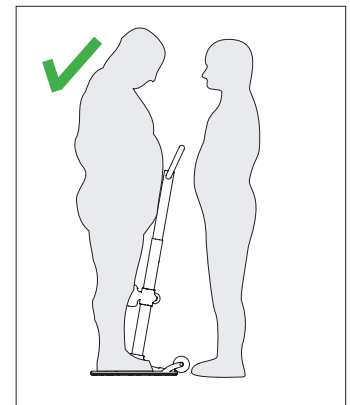
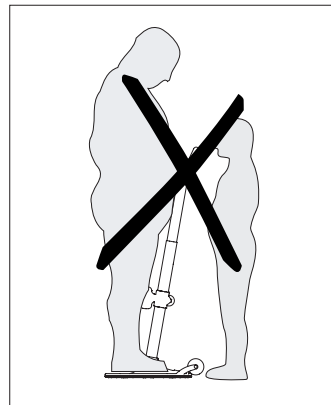

Avustajan on pystyttävä käsittelemään käyttäjän painoa.

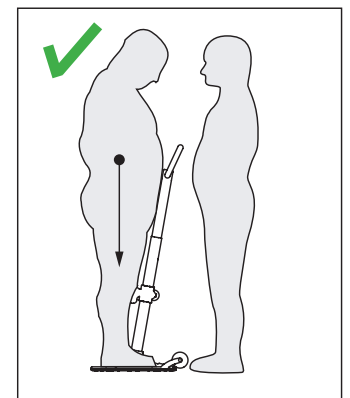
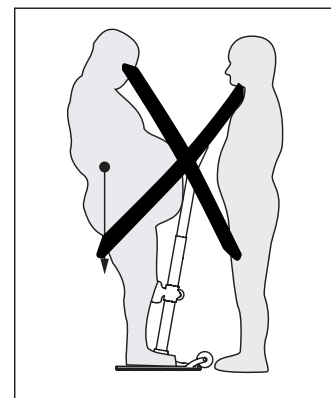

Varmista, että käyttäjän paino asettuu pohjalevyn sisälle.

## Puhdistus ja desinfiointi

Puhdista säännöllisesti. Puhdista pinnat kostealla liinalla käyttäen asianmukaista, pH-arvoltaan neutraalia puhdistusainetta. Älä käytä liuottimia tai vahvoja nesteitä, sillä tämä voi vahingoittaa Turnerin pintoja. Käytä tarvittaessa desinfiointiin isopropyylialkoholia tai vastaavaa ainetta. Vältä hankaavia puhdistustuotteita. Poista hiukset ja lika pyöristä ja varmista, että pyörät rullaavat vapaasti.



Varmista, ettet vaurioita tai irrota tarroja puhdistuksen yhteydessä

## Kunnostus

Noudata puhdistus- ja asennusohjeita. Erillinen kunnostusdokumentti on saatavana osoitteessa Etac.com.

## Kierrätys

Turner PRO voidaan hävittää metallijätteenä. Kierrätysohjeet ovat saatavana osoitteessa Etac.com

## Varaosat

Varaosaluettelo on saatavana osoitteessa Etac.com.

## Allgemeines

	<p><b>CE-Erklärung</b> Das Produkt und das entsprechende Zubehör, die in dieser Bedienungsanleitung beschrieben werden, entsprechen der Verordnung (EU) 2017/745 von 5. April 2017 - als Medizinprodukt, Risikoklasse I. Das Produkt wird gemäß EN 12.82.2012 und ausgewählten Abschnitten von EN/ISO 10.35.2006 hergestellt und geprüft. Jeder schwere Zwischenfall, der im Zusammenhang mit dem Produkt auftritt, sollte dem Hersteller und der zuständigen Behörde des Mitgliedstaats, in dem der Anwender und/oder Patient niedergelassen ist, gemeldet werden.</p>
---	---

### Voraussetzungen für die Nutzung:

Ein Patiententransfer stellt immer ein gewisses Risiko dar. Das in dieser Gebrauchsanweisung beschriebene Gerät darf daher nur von entsprechend geschultem Personal verwendet werden.

### Garantiehinweis

2 Jahre Garantie auf Verarbeitungs- und Materialfehler unserer Produkte. Unsere Allgemeinen Geschäftsbedingungen finden Sie unter [www.etac.com](http://www.etac.com).

Besuchen Sie uns auf [www.etac.de](http://www.etac.de) und laden Sie sich die neueste Version unserer Dokumentation herunter.

## Wichtige Hinweise

Diese Gebrauchsanweisung enthält wichtige Hinweise und Informationen für den sicheren Gebrauch des Turner PRO und des Zubehörs. In dieser Bedienungsanleitung bezeichnet „Benutzer“ diejenige Person, die transferiert wird.

Der „Helfer“ ist diejenige Person, die den Turner PRO bedient.



Dieses Symbol weist auf wichtige Sicherheitshinweise hin. Befolgen Sie diese Anweisungen bitte genau.



Lesen Sie vor dem Gebrauch die Gebrauchsanweisung! Es ist sehr wichtig, dass Sie vor Inbetriebnahme des Geräts mit dem Inhalt der Gebrauchsanweisung genau vertraut sind.

### Modifikationen und Verwendung von Komponenten anderer Hersteller:

Wir empfehlen die ausschließliche Verwendung von Etac-Komponenten und -Ersatzteilen. Wenn am Produkt Modifikationen vorgenommen werden, erlischt die Konformitätserklärung und die von Etac auf das Produkt gegebene Garantie. Für Probleme oder Unfälle, die bei der Verwendung von Komponenten anderer Hersteller auftreten, haftet Etac nicht.

### Bewerten Sie die Risiken und machen Sie entsprechende Notizen.

Als Helfer sind Sie für die Sicherheit des Benutzers verantwortlich!

## Risikobewertung



Nur technischem Personal ist die Durchführung von Reparaturen gestattet.

## Beschriftungen und Symbole

### Produktetikett:

Das Etikett gibt Auskunft über die Artikel- und Seriennummer (Barcodes). Der EAN-Code besteht aus:

(01) (EAN nummer.): xxxxxxxx

(11) (Charge): JJMMTT

(21) (Seriennummer): xxxxxx



### Symbole:

Die auf dem Produkt verwendeten Symbole haben folgende Bedeutung:



Hersteller



Herstellungsdatum



Katalognummer



Seriennummer



Medizinprodukt



CE-konform



Lesen Sie die Gebrauchsanweisung



Max. Reinigungstemperatur



Max. Benutzergewicht (Tragfähigkeit)



ph-Wert bei der Reinigung



QR-Code

### Kurzanleitung:

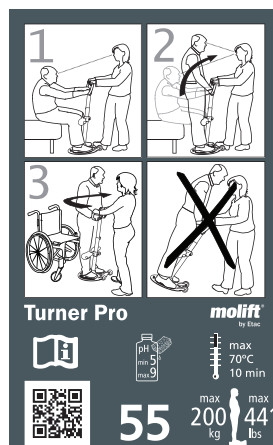

## Turner PRO – Verwendungszweck

Der Turner Pro ist eine Aufsteh- und Umsetzhilfe, die es der Pflegekraft erleichtert, dem Patienten beim Aufstehen und Umsetzen zu helfen. Der Turner Pro ist für Patienten geeignet, die aus eigener Kraft in der Lage sind, zu greifen, sich festzuhalten und sich in eine aufrechte Position zu ziehen, jedoch beim Aufstehen und Umsetzen auf Hilfe angewiesen sind. Das Gerät dient dem Umsetzen einer Person in/aus ein/em Bett bzw. in/aus einen/m Stuhl, Rollstuhl oder Toilettensitz. Der Turner PRO besteht aus leichtgewichtigen Materialien und kann problemlos umherbewegt werden. Der Turner PRO darf nur in Innenräumen und auf ebenen Flächen verwendet werden.

### Kontraindikationen

Der Turner PRO darf bei Nutzern, die nicht selbständig steh- und/oder greiffähig sind, nicht eingestetzt werden.

## Turner PRO

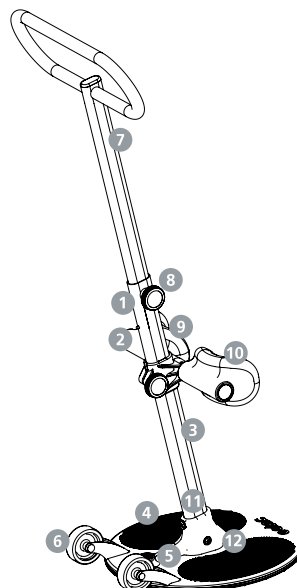

1. Äußerer Schaft
2. Verriegelungsstift
3. Höhenetikett
4. Grundplatte
5. Fußablage
6. Transportrollen
7. Innerer Schaft mit Griff
8. Drehknopf
9. Kurzanleitung
10. Beinauflage
11. Produktetikett
12. Schrauben



**Technische Daten**

**Sichere Traglast (SWL, Safe Working Load):** Werkstoffe:

200 kg (441 lbs)

Pulverbeschichtetes Aluminium, Kunststoff, Stahl.

**Gewicht des Geräts:**

8kg

**Abmessungen:**

- Höhe (A): 0,8 bis 1,2 m
- Höhe (B): 0,3 bis 0,55 m
- Tiefe (C): 0,46 m
- Breite (D): 0,45 m
- Fußplatte (Ø): 0,40 m

**Erwartete Lebensdauer:**

Der Turner PRO hat eine voraussichtliche Lebensdauer von 15 000 Drehzyklen bzw. 5 Jahren.

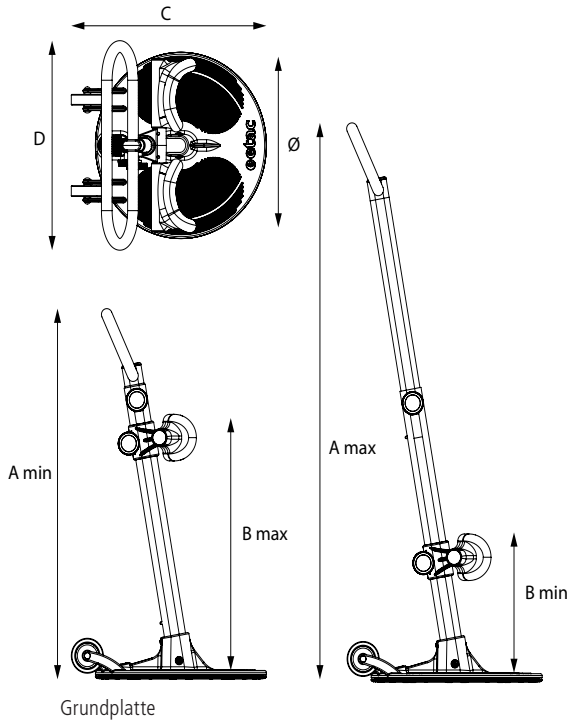

**Die Montage der Beinlaufflage**

Die Kniekissen sind individuell anpassbar. Die Beinauflage ist in einem Bereich von 0,3 bis 0,55 Metern stufenlos anpassbar. Bei der Montage der Beinauflage sind die folgenden zwei Schritte zu befolgen:

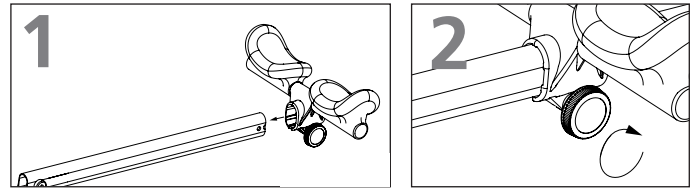

1. Legen Sie den Schaft auf einer ebenen Fläche ab. Führen Sie die Beinauflage darüber, wobei die Kniekissen nach oben zeigen müssen. Stellen Sie sicher, dass sich beide Knöpfe auf derselben Seite befinden.

2. Ziehen Sie den Knopf fest, indem Sie ihn im Uhrzeigersinn drehen.

**Montage des Schaftes an der Grundplatte**

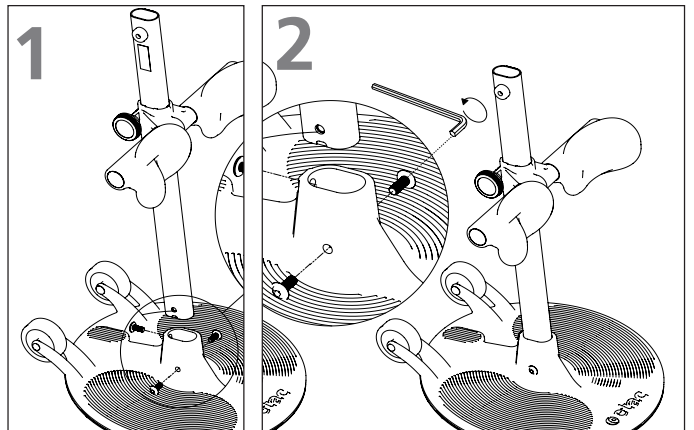

1. Legen Sie die Grundplatte auf einer ebenen Fläche ab. Führen Sie den Schaft ein, wobei die Kniekissen in die den Rädern entgegengesetzte Richtung zeigen müssen.

2. Führen Sie alle drei Schrauben in ihre Öffnungen in der Grundplatte ein. Schrauben Sie diese mit einem Inbusschlüssel ein. Ziehen Sie die Schrauben fest an.

**Werkstoffe**

Pulverbeschichtetes Aluminium (Grundplatte und unterer äußerer Schaft), Stahl (Innerer und äußerer Schaft, Schrauben, Muttern, Verbindungsstücke)

Alle weiteren Teile und Verkleidungen sind aus Kunststoff (POM, PDHD, ABS, PE-LLD) verarbeitet.

Durch die Pulverbeschichtung und den Chrom, sind die Metalle vor Korrosion geschützt.

**Stellen Sie sicher, dass alle drei Schrauben fest sitzen. Lose Schrauben können zu einer Instabilität des Schaftes führen, sodass die Verwendung des Turner PRO nicht sicher wäre.**

**Mitgelieferte Teile**

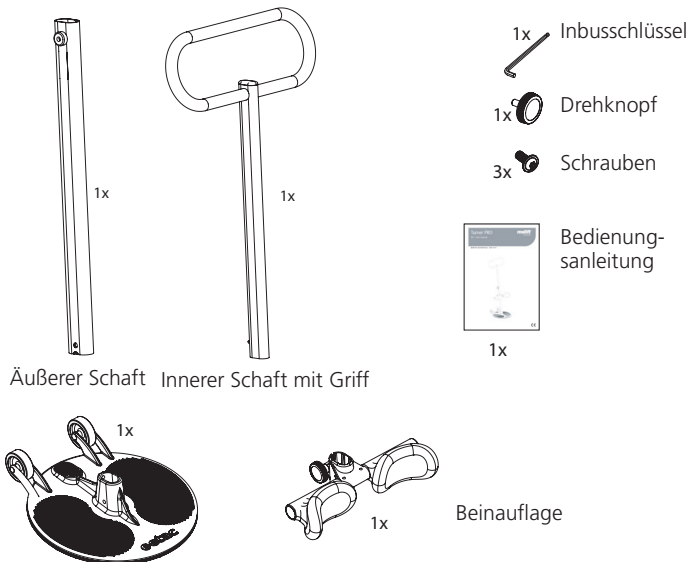

**Die Montage des Griffs**

Der Griff ist in einem Bereich von 0,8 bis 1,2 Metern stufenlos anpassbar. Bei der Montage des Griffs sind die folgenden drei Schritte zu befolgen:

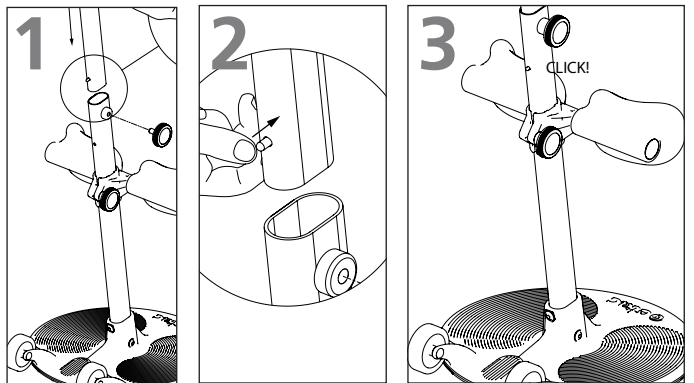

1. Platzieren Sie den Griff so, dass der Verriegelungsstift in Richtung der Räder zeigt.

2. Drücken Sie auf den Verriegelungsstift und schieben Sie den oberen Schaft in den bereits zusammengesetzten unteren Schaft.

3. Der Handgriff sitzt korrekt, sobald ein Klickgeräusch zu hören ist. Drehen Sie am Knopf und ziehen Sie ihn fest

Checkliste nach der Montage



Nehmen Sie den Turner PRO erst in Gebrauch, wenn Sie nach der Montage die folgende Checkliste durchgegangen sind.

Vergewissern Sie sich vor der Inbetriebnahme anhand dieser Checkliste, dass der Turner PRO ordnungsgemäß montiert ist und gefahrlos benutzt werden kann. Details zur korrekten Montage finden Sie auf der vorherigen Seite.

Stellen Sie sicher, dass die Beinauflage korrekt montiert ist. rt ist.

Stellen Sie sicher, dass alle drei Schrauben zwischen dem äußeren Schaft und der Grundplatte vorschriftsmäßig montiert und festgezogen sind.

Stellen Sie sicher, dass der Griff (also der innere Schaft) korrekt montiert ist.

Vergewissern Sie sich, dass sich der Turner PRO ungehindert drehen lässt.

Anpassen der Griffhöhe

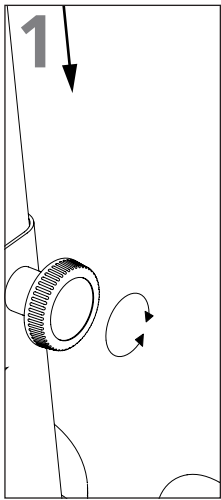

1. Drehen Sie den Knopf entgegen dem Uhrzeigersinn und stellen Sie die gewünschte Griffhöhe ein.

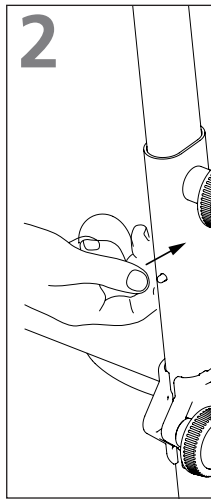

2. Drücken Sie auf den Sperrstift, wenn sich der Griff-Schaft noch darüber befindet.

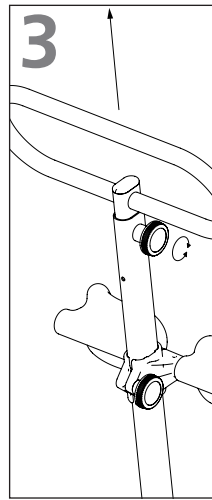

3. Sobald die gewünschte Griffhöhe erreicht ist, drehen Sie den Knopf im Uhrzeigersinn, um ihn in dieser Höhe zu arretieren.



Achten Sie bei der Höhenverstellung auf den Griff. Er kann herunterrutschen und die Bedienperson am Kopf oder Oberkörper treffen.



Verwenden Sie den Griff nicht, wenn er sich in einer Position oberhalb der Stiftverriegelungsposition befindet. Dies führt zu einer Instabilität des Schaftes, sodass die Verwendung des Turner PRO nicht sicher wäre.

Das Anpassen der Beinlaufage

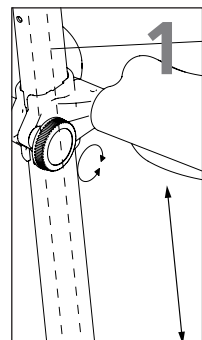

1. Drehen Sie den Knopf entgegen dem Uhrzeigersinn und stellen Sie die gewünschte Höhe der Beinstütze ein.

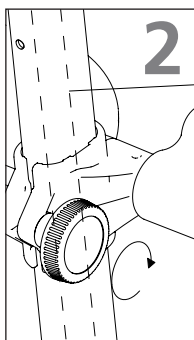

2. Sobald die gewünschte Höhe der Beinstütze erreicht ist, drehen Sie den Knopf im Uhrzeigersinn, um sie in dieser Höhe zu arretieren.

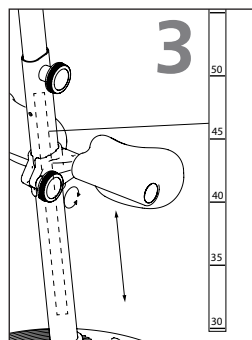

3. Die Höhe der Beinstütze kann auf der Skala am Schaft abgelesen werden. Die Zahl oberhalb der Beinauflagenhalterung gibt die jeweilige Höhe an.



Stellen Sie sicher, dass die Knöpfe richtig festgezogen sind. Wenn ein Knopf nur lose angezogen ist, kann der Griff oder die Beinstütze herunterrutschen, sodass der Turner Pro nicht gefahrlos benutzt werden kann.

Die Positionierung des Turner PRO



1. Positionieren Sie die neue Sitzgelegenheit (Stuhl, Rollstuhl, Toilettensitz oder Bett) zum bisherigen Sitz.

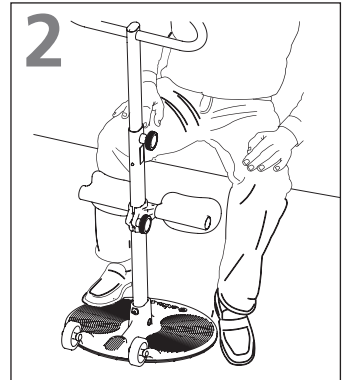

2. Schieben Sie den Turner PRO unter die Füße des Benutzers.

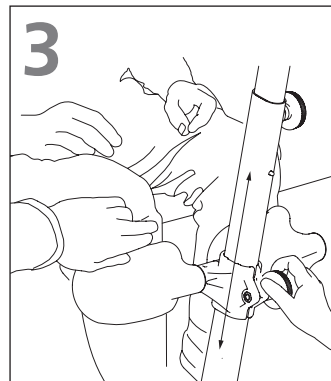

3. Passen Sie die Höhe der Beinauflage so an, dass sich diese zwei Finger unterhalb der Kniescheibe des Benutzers befindet.

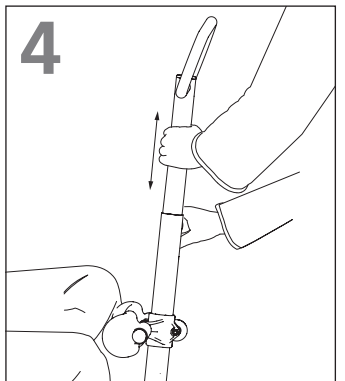

4. Stellen Sie den Griff auf eine für den Patienten und die Pflegekraft bequeme Höhe ein.

Transport und Lagerung

Der Turner PRO kann bei Umgebungstemperaturen von -25 bis +70 °C und bei einer relativen Luftfeuchtigkeit von 15 bis 93 % gelagert und transportiert werden.

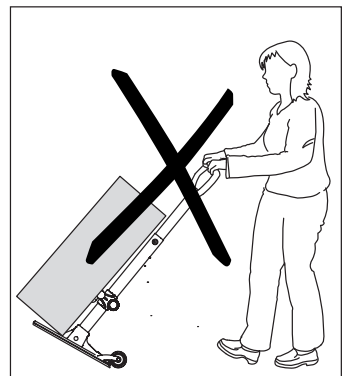

Verwenden Sie den Turner PRO nicht, um Personen oder Gegenstände zu befördern.

Der Patiententransfer

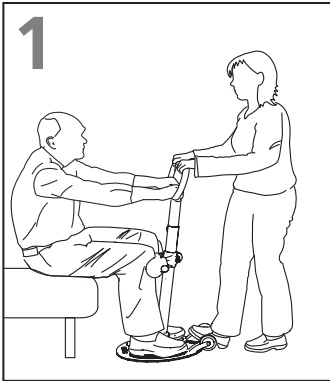

1. Fassen Sie den Griff mit beiden Händen und stellen Sie einen Fuß auf die Fußablage. Der Nutzer fasst den Griff, wenn möglich, mit beiden Händen.

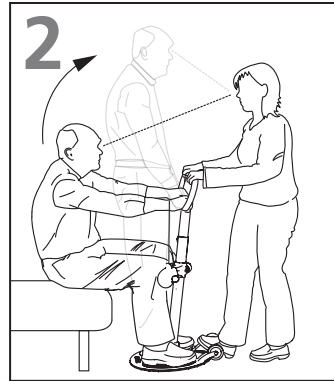

2. Lassen Sie den Benutzer aufstehen und balancieren Sie das Gewicht des Benutzers gleichzeitig mit einem Fuß und den Händen aus (als Gegengewicht den eigenen Körper zurücklehnen).

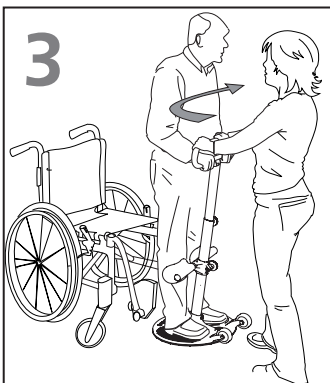

3. Drehen Sie den Turner PRO so, dass der Benutzer vor seine neue Sitzgelegenheit transferiert wird.

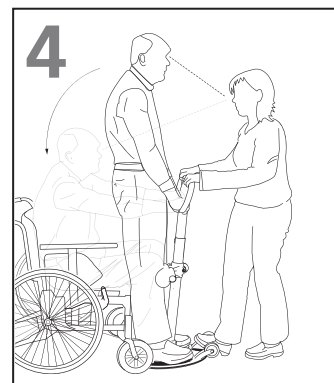

4. Treten Sie auf die Fußstütze, nehmen Sie sicheren Stand ein und bitten Sie den Benutzer, sich zu setzen. Halten Sie während des gesamten Ablaufs stets Blickkontakt zum Benutzer.



Stellen Sie sicher, dass sich das Gewicht des Benutzers innerhalb der Fläche der Grundplatte befindet.

Reinigung und Desinfizierung

Reinigung

Beachten Sie die Angaben des Reinigungs- und Desinfektionsmittelherstellers. Falls erforderlich, verwenden Sie geeignete Schutzkleidung, wie Kittel, Schutzbrille und Handschuhe.

Reinigen Sie das Gerät regelmäßig. Grobe Verschmutzungen des Geräts sind unmittelbar nach der Anwendung zu entfernen.

Säubern Sie die Oberflächen mit einem feuchten Tuch und mithilfe eines geeigneten pH-neutralen Reinigers. Verwenden Sie keine Reinigungsmittel auf Basis von Chlor, Aceton oder Benzol. Verzichten Sie auf den Einsatz von Lösungsmitteln und scharfen Reinigungsmitteln, Scheuermittel, ätzende Substanzen, Säuren oder Bleiche, Verwenden Sie keine Hochdruck- oder Dampfreiniger. Ansonsten können diese die Oberfläche des Turners beschädigen.

Achten Sie darauf, alle Oberflächen des Gerätes gründlich zu säubern. Reinigungsmittelrückstände können anschließend mit einem feuchten Tuch entfernt werden.

Entfernen Sie Haare und Fusseln von den Rädern und überprüfen Sie die Räder auf reibungslosen Lauf.

Desinfektion

Benutzen Sie Isopropylalkohol. Beachten Sie die Konzentration und Einwirkzeiten des Desinfektionsmittelherstellers. Das Gerät

eignet sich zur Sprüh- und Wischdesinfektion mit handelsüblichen Desinfektionsmitteln. Alle Flächen sind mit einem mit Desinfektionsmittel angefeuchteten, sauberen Tuch abzuwischen. Benutzen Sie das Gerät gleichmäßig mit Desinfektionsmittel. Spülen Sie das Desinfektionsmittel nicht nach und lassen Sie das Gerät an der Luft trocknen. Anschließend ist das Gerät auf Sauberkeit und Beschädigungen zu überprüfen.

Benutzer/Helfer

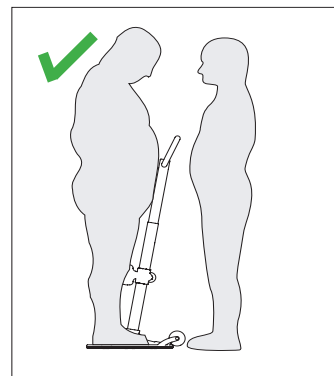
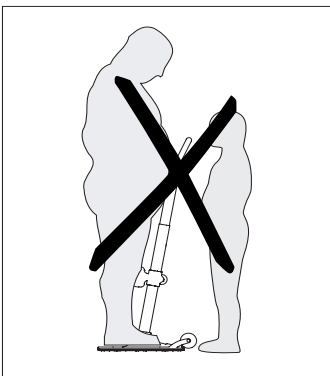

Der Helfer muss das Gewicht des Benutzers bewältigen können.

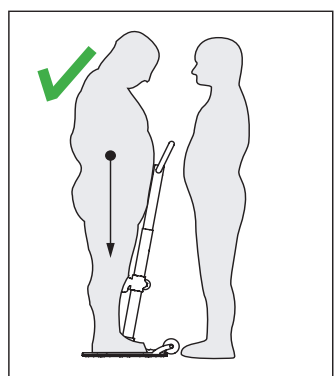
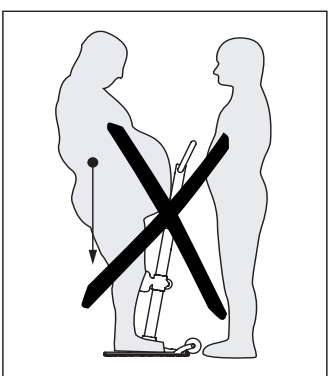

Stellen Sie sicher, dass bei der Reinigung die Etiketten nicht beschädigt oder entfernt werden

Instandsetzung

Der Turner PRO ist wartungsfrei. Das Gerät ist für den Wiedereinsatz geeignet. Vor einem Patientenwechsel oder Wiedereinsatz befolgen Sie die Anweisungen zur Reinigung und Desinfektion sowie der Montage und Anpassung. Ein separates Instandsetzungsdokument ist auf [www.etac.com](http://www.etac.com) verfügbar.

Recycling

Der Turner PRO kann als Metallschrott entsorgt werden. Recyclinganweisungen sind auf [Etac.com](http://Etac.com) verfügbar.

Ersatzteile

Eine Ersatzteilliste ist auf [Etac.com](http://Etac.com) verfügbar.

EN  
SV  
NO  
DA  
FI  
DE  
NL  
FR  
IT  
ES

## Algemeen

### CE-verklaring

Het product en de bijbehorende accessoires die in deze gebruiksaanwijzing worden beschreven, voldoen aan Verordening (EU) 2017/745 van 5 april 2017 – als medisch hulpmiddel, risicoklasse I. Het product is geproduceerd en getest volgens EN 12182:2012 en bepaalde delen van EN/ISO 10535:2006.

Elk ernstig incident dat zich voordoet in verband met het hulpmiddel moet worden gemeld aan de fabrikant en de bevoegde autoriteit van de lidstaat waar de gebruiker en/of patiënt is gevestigd.



### Gebruiksvoorwaarden:

Het verplaatsen van een persoon kan risico's met zich meebrengen. Daarom mag alleen goed opgeleid personeel het hulpmiddel uit deze bedieningshandleiding gebruiken.

### Garantieverklaring

Wij bieden op onze producten een garantie van twee jaar tegen materiaal- en fabricagefouten. Ga naar [www.etac.com](http://www.etac.com) voor de voorwaarden.

Op [www.etac.com](http://www.etac.com) kunt u de laatste versie van onze documentatie downloaden.

## Belangrijk

In deze bedieningshandleiding staan belangrijke veiligheidsinstructies en informatie over het gebruik van de Turner PRO en de accessoires. In deze handleiding is de gebruiker de persoon die wordt verplaatst. De assistent is de persoon die de Turner PRO bedient.



Dit symbool geeft belangrijke informatie over de veiligheid aan. Volg deze instructies zorgvuldig.



Lees de bedieningshandleiding vóór gebruik! Het is belangrijk dat u de inhoud van de bedieningshandleiding volledig begrijpt voordat u het hulpmiddel gebruikt

### Aanpassingen en gebruik van onderdelen van andere fabrikanten:

We raden u aan om uitsluitend Etac-onderdelen en reserveonderdelen te gebruiken. Als er aanpassingen aan het product worden uitgevoerd, vervalt de conformiteitsverklaring en kunnen er geen garantieclaims bij Etac worden ingediend. Etac is niet aansprakelijk voor fouten of ongevallen door het gebruik van onderdelen van andere fabrikanten.

## Risicobeoordeling

Evalueer het risico en maak aantekeningen.

U bent als assistent verantwoordelijk voor de veiligheid van de gebruiker!



Alleen technisch personeel mag reparaties uitvoeren.

## Labels en symbolen

### Productlabel:

Het label bevat het artikelnummer en het serienummer (streepjescodes) De EAN-code bevat:

(01) (EAN nr.): xxxxxxxxxxxxxx

(11) (batch): JJMMDD

(21) (serienummer): xxxxxx



### Symbolen:

Uitgebreide uitleg van de symbolen die op het product worden gebruikt:



Fabrikant



Productiedatum



Catalogusnummer



Serienummer



Medisch hulpmiddel



CE-markering



Zie de bedieningshandleiding



Max. temperatuur bij het wassen



Max. gewicht gebruiker (veilige belasting):



pH bij het wassen



QR code

### Beknopte bedieningshandleiding:

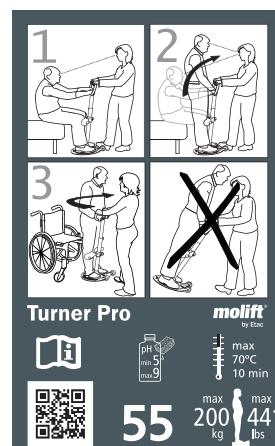

## Turner PRO - beoogd gebruik

Turner Pro is een sta-op-en transferhulp die het voor een verzorger makkelijker maakt om een gebruiker te helpen overeind te komen en hem/haar in een andere zitpositie te brengen. Het product is bedoeld voor personen die het hulpmiddel kunnen vastgrijpen en in staat zijn om hun eigen lichaamsgewicht te dragen, maar die wel ondersteuning/hulp nodig hebben om te gaan staan en te draaien. De voorziening is bedoeld voor de transfer van personen van/naar een bed, stoel, rolstoel of toilet. De Turner PRO is gemaakt van lichte materialen en kan eenvoudig naar nieuwe locaties worden verplaatst. De Turner PRO mag alleen binnen en op een vlakke ondergrond worden gebruikt.

## Turner PRO

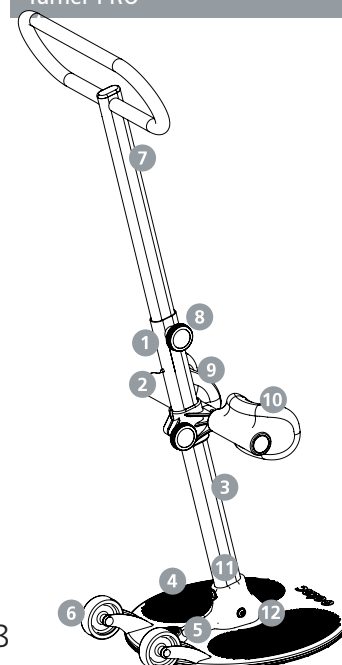

1. Buitenste stang
2. Borgpen
3. Hoogtelabel
4. Hoofdplaat
5. Voetsteun voor assistent
6. Transportwielen
7. Binnenste stang met handgreep
8. Draaiknop
9. Beknopte bedieningshandleiding
10. Beensteun beensteun
11. Productlabel
12. Bouten

### Technische gegevens

**Veilige werkbelasting (VWB - SWL, Safe Working Load):**

200 kg (441 lbs)

**Gewicht van eenheid:**

8kg

**Afmetingen:**

Hoogte (A): 0,8-1,2 m

Hoogte (B): 0,3-0,55 m

Diepte (C): 0,46 m

Breedte (D): 0,45 m

Voetplaat (Ø): 0,40 m

**Materiaal:**

Gepoedercoat aluminium, kunststof, staal.

**Verwachte levensduur:**

De Turner PRO heeft een verwachte levensduur van 5 jaar of 15.000 draaicycli.

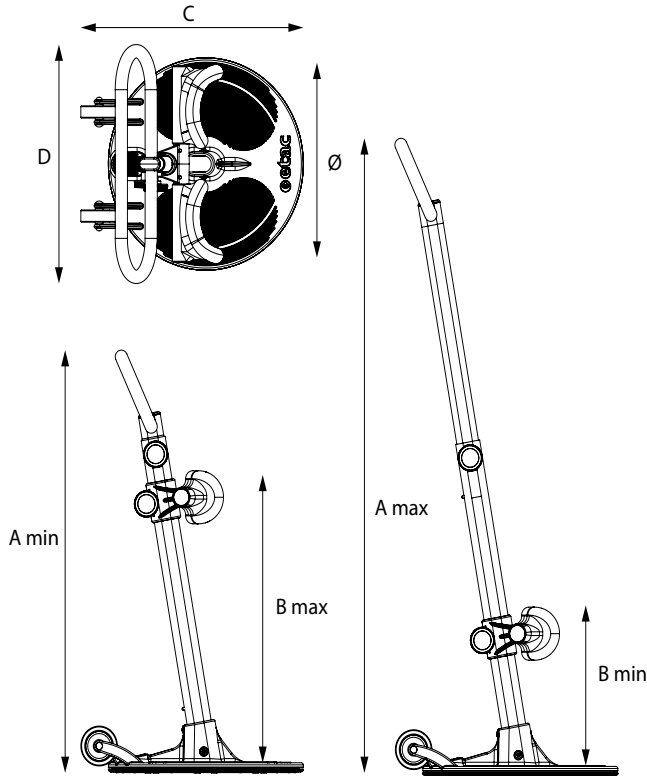

### Geleverde onderdelen

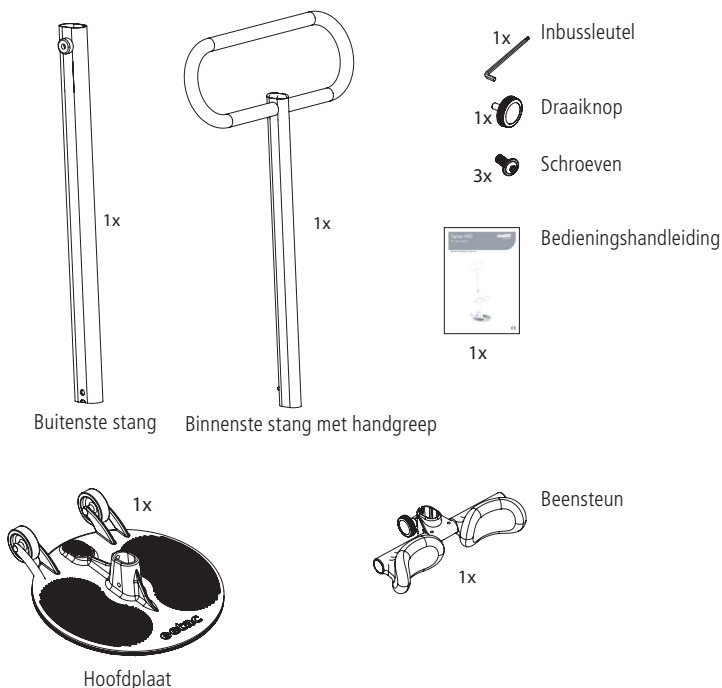

### De beensteun monteren

De kniekussens zijn individueel verstelbaar. De beensteun is traploos verstelbaar van 0,3 tot 0,55 meter. Volg deze drie stappen om de beensteun te monteren:

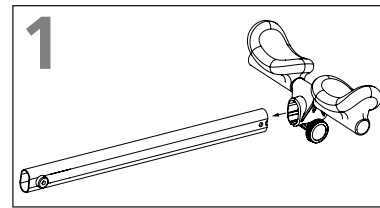

Leg de stang op een vlakke ondergrond. Bevestig de beensteun met de kniekussens naar boven. Zorg ervoor dat beide draaiknoppen zich aan dezelfde kant bevinden.

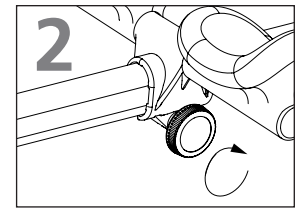

Draai de knop vast door met de klok mee te draaien.

### De stang aan de hoofdplaat bevestigen

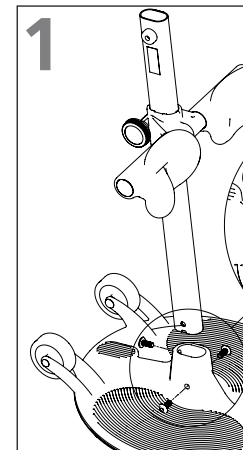

Plaats de hoofdplaat op een vlakke ondergrond. Steek de stang in het gat met de kniekussens weg van de wielen gericht.

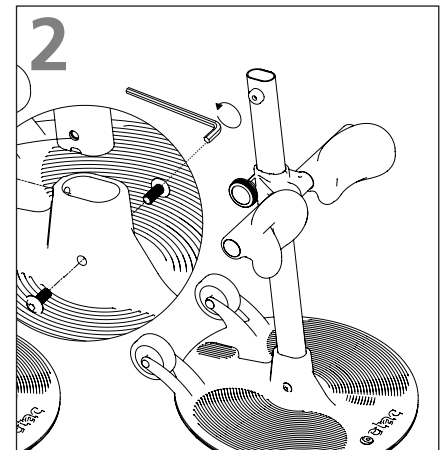

Steek alle drie de bouten in de gaten in de hoofdplaat. Schroef de bouten stevig vast met de inbusleutel.



**Zorg ervoor dat de bouten alle drie goed zijn vastgedraaid. Losse bouten kunnen de stang onstabiel maken, waardoor het gebruik van de Turner PRO onveilig wordt.**

### De handgreep bevestigen

De handgreep is traploos verstelbaar van 0,8 tot 1,2 meter. Volg deze drie stappen om de handgreep te monteren:

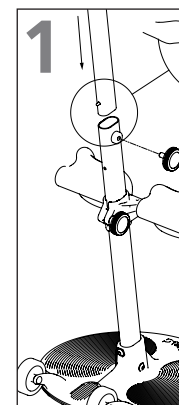

Plaats de handgreep zodanig dat de borgpen naar de wielen wijst.

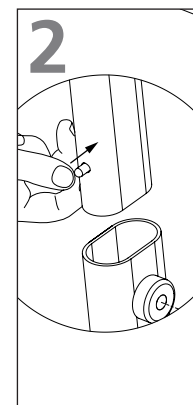

Druk de borgpen in en schuif de stang van de handgreep in de bevestigde stang.

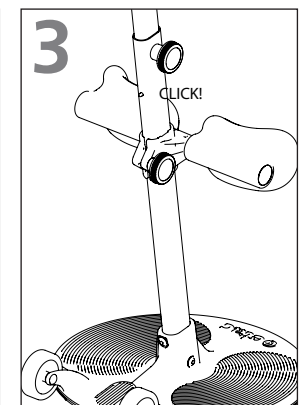

Hij is correct gemonteerd als er een klik hoorbaar is. Draai de knop vast.

## Controlelijst na montage



Voer na de montage altijd eerst een volledige controle aan de hand van de controlelijst uit, voordat u de Turner PRO gebruikt.

Gebruik deze controlelijst om te controleren of de Turner PRO goed is gemonteerd en veilig werkt voordat u hem gebruikt. Zie voor meer details de montage-instructies op de vorige pagina

- Zorg ervoor dat de beensteun correct is gemonteerd
- Zorg ervoor dat alle drie de bouten tussen de buitenste stang en de hoofdplaat correct zijn gemonteerd en goed zijn vastgedraaid.
- Zorg ervoor dat de handgreep (binnenste stang) correct is gemonteerd.
- Zorg ervoor dat de Turner vrij kan draaien.

## De hoogte van de handgreep afstellen

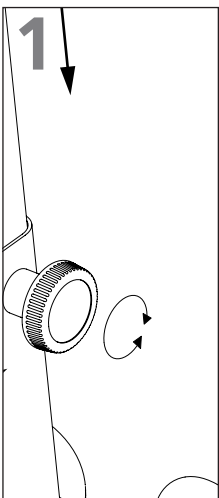

Draai de knop tegen de klok in en plaats de handgreep op de gewenste hoogte.

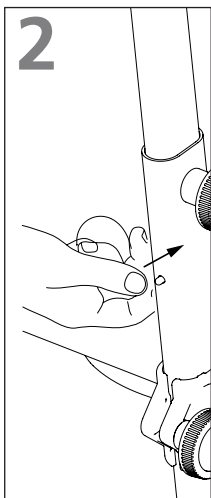

Druk de borgpen in wanneer de handgreep in de hoogste stand staat

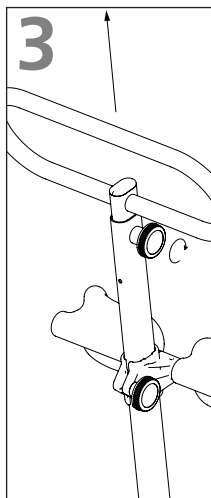

Als u de handgreep op de juiste hoogte hebt geplaatst, draai de knop dan met de klok mee om de stand vast te zetten.



Pas op voor de handgreep tijdens het afstellen van de hoogte. De handgreep kan omlaag glijden en het hoofd of bovenlichaam van de bediener raken.



Stel de handgreep niet af op een stand boven de plaats van de borgpen. Zo wordt de stang namelijk onstabiel, waardoor het gebruik van de Turner onveilig wordt.

## De hoogte van de beensteun aanpassen

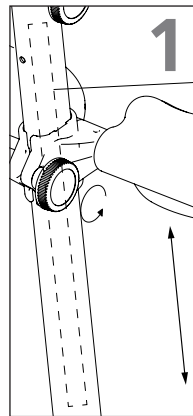

Draai de knop tegen de klok in en plaats de kniesteun op de gewenste hoogte.

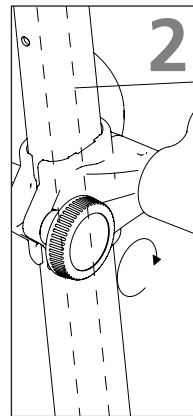

Als u de kniesteun op de juiste hoogte hebt geplaatst, draai de knop dan met de klok mee om de stand vast te zetten.

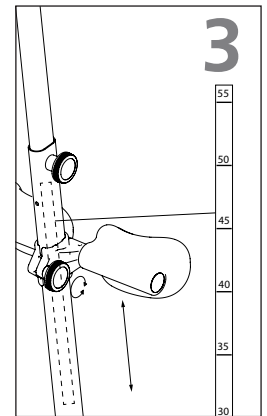

De hoogte van de kniesteun kunt u aflezen van de schaalverdeling op de stang. Het nummer boven de kniesteunbeugel geeft de correcte hoogte aan.



Zorg ervoor dat de knoppen goed zijn vastgedraaid. Door losse draaiknoppen kan de handgreep of de kniesteun omlaag glijden, wat het gebruik van de Turner onveilig maakt.

## Plaatsing van de Turner PRO



Plaats de nieuwe zitplaats (stoel, rolstoel, toilet of bed) haaks (90 graden) op de huidige zitplaats

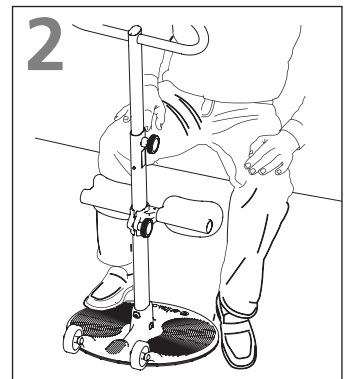

Schuif de Turner PRO tot onder de voeten van de gebruiker.

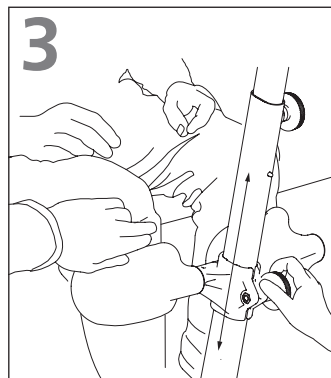

Stel de hoogte van de beensteun zodanig in dat de beensteun zich twee vingers onder de knieschijf van de gebruiker bevindt

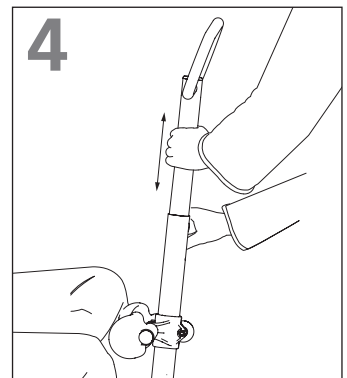

Stel de hoogte van de handgreep in op een positie die zowel voor de gebruiker als de assistent prettig is.

### Transport en opslag

De Turner PRO kan worden opgeslagen en vervoerd bij temperaturen tussen -25 en 70 °C en bij een relatieve vochtigheid tussen 15 en 93%.

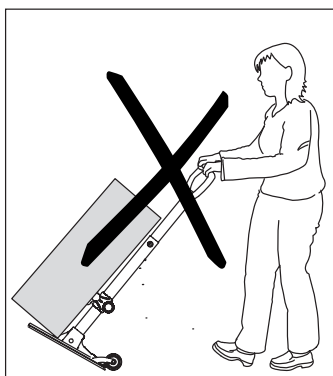

Gebruik de Turner PRO niet voor het vervoeren van personen of goederen.

### De gebruiker verplaatsen

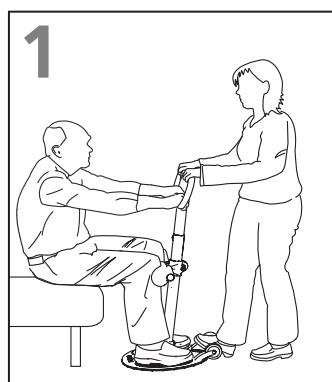

1 Grijp de handgreep met beide handen vast en plaats één voet op de voetsteun. De gebruiker pakt de handgreep vast, indien mogelijk met beide handen.

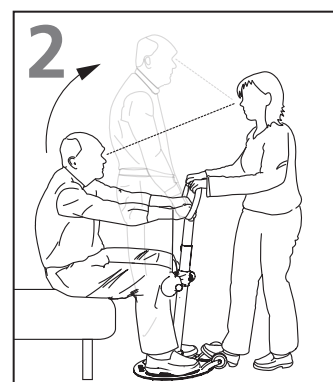

2 Moedig de gebruiker aan om op te staan terwijl u tegelijkertijd het gewicht van de gebruiker opvangt met behulp van uw voet en uw handen (gebruik uw lichaamsgewicht door achterover te leunen).



3 Draai de Turner PRO zodat de gebruiker wordt verplaatst naar de voorzijde van de nieuwe zitplaats.

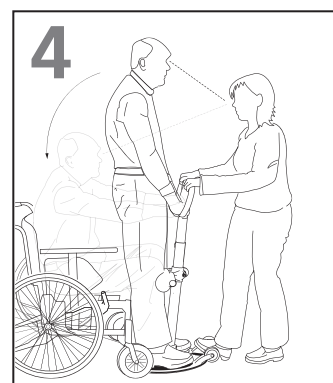

4 Plaats uw voet op de voetsteun, zet u schrap en vraag de gebruiker om te gaan zitten. Zorg ervoor dat u gedurende het gehele transferproces oogcontact houdt met de gebruiker.

### Gebruiker / assistent

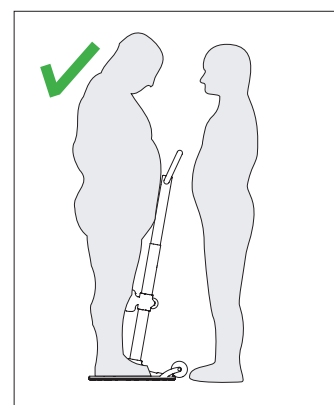
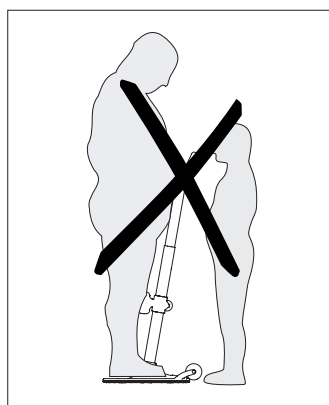

De assistent moet het gewicht van de gebruiker kunnen opvangen.

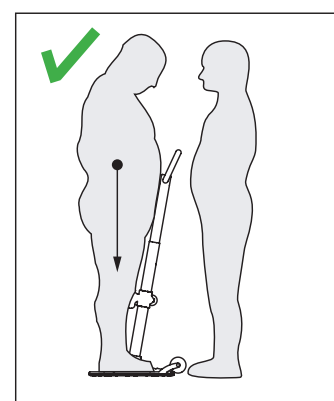
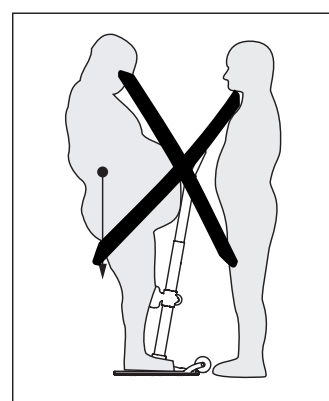

Zorg ervoor dat het gewicht van de gebruiker op de hoofdplaat rust.

### Reiniging en desinfectie

Reinig het product regelmatig. Reinig oppervlakken met een vochtige doek en een geschikt pH-neutraal reinigingsmiddel. Gebruik geen oplosmiddelen of agressieve middelen omdat de oppervlakken van de Turner hierdoor beschadigd kunnen raken. Voor desinfectie wanneer nodig: gebruik isopropylalcohol of een vergelijkbaar middel. Gebruik geen agressieve reinigingsmiddelen. Verwijder haren en pluis uit de wielen en controleer of ze vrij kunnen draaien.



Zorg ervoor dat u tijdens het reinigen geen labels beschadigt of verwijdert.

### Gebruiksklaar maken

Volg de reinigings- en montageprocedure. Op etac.com vindt u een speciaal document over het gebruiksklaar maken.

### Recyclage

Turner PRO kan worden afgevoerd als metaalafval. Instructies voor recycling vindt u op etac.com.

### Reserveonderdelen

Op etac.com is een lijst met reserveonderdelen beschikbaar.

Général

	<p><b>Déclaration CE</b>                  Le produit et ses accessoires, décrits dans le présent mode d'emploi, sont conformes au règlement (UE) 2017/745 du 5 avril 2017 à titre de dispositif médical de classe I.                  Le produit est fabriqué et testé conformément à la norme EN 12182:2012 et à certaines parties de la norme EN/ISO 10535:2006.                  Tout incident grave survenant en lien avec le dispositif doit être signalé au fabricant et à l'autorité compétente de l'État membre dans lequel l'utilisateur et/ou le patient est établi.</p>
---	--

Conditions d'utilisation :

Le transfert de personnes peut comporter des risques. Seul du personnel formé est autorisé à utiliser l'équipement présenté dans ce manuel d'utilisation.

Avis de garantie

Garantie de deux ans contre les vices de fabrication et les défauts matériels de nos produits.

Pour connaître les conditions générales, veuillez consulter le site [www.etac.com](http://www.etac.com).

Rendez-vous sur [www.etac.com](http://www.etac.com) pour télécharger la dernière version de notre documentation.

Important

Ce manuel d'utilisation contient des instructions de sécurité et des informations importantes relatives à l'utilisation du Turner PRO et des accessoires. Dans ce manuel, l'« utilisateur » désigne la personne transférée.

L'« assistant » est la personne actionnant le Turner PRO

	<p><b>Ce symbole signale des informations importantes liées à la sécurité. Veuillez les suivre attentivement.</b></p>
---	---

	<p><b>Lisez le manuel d'utilisation avant utilisation ! Il est important de comprendre parfaitement le contenu du manuel d'utilisation avant de tenter d'utiliser l'équipement.</b></p>
---	---

Modifications et utilisation de composants conçus par d'autres fabricants :

Nous recommandons d'utiliser uniquement des composants et des pièces de rechange Etac. La déclaration de conformité n'est pas valable et Etac ne prend pas en charge la garantie si des modifications sont apportées au produit. Etac ne peut être tenu responsable des pannes ou des accidents pouvant se produire lors de l'utilisation de composants d'autres fabricants.

Évaluation des risques

Évaluez les risques et prenez des notes.

En tant qu'assistant, vous êtes responsable de la sécurité de l'utilisateur !

	<p><b>Seul le personnel technique est autorisé à réaliser des opérations de réparation..</b></p>
---	--

Étiquettes et symboles

Étiquette du produit :

L'étiquette comporte le numéro de l'article et le numéro de série (code-barres). Le code EAN comporte ;

(01) (01) (no EAN) xxxxxxxxx











(11) (Lot) : AAMMJJ

(21) (Numéro de série) : xxxxx



Symboles :

Symboles utilisés sur le produit, expliqués en détail :

-  Fabricant
-  Date de fabrication  
YYYY-MM-DD
-  Référence catalogue
-  Numéro de série
-  Dispositif médical
-  Marquage CE
-  Consultez le manuel d'utilisation
-  Température maximale de nettoyage  
max 70°C  
10 min
-  Poids max. de l'utilisateur :  
max 200 kg / max 441 lbs
-  pH au nettoyage  
pH max 9
-  QR Code

Guide d'utilisation rapide :

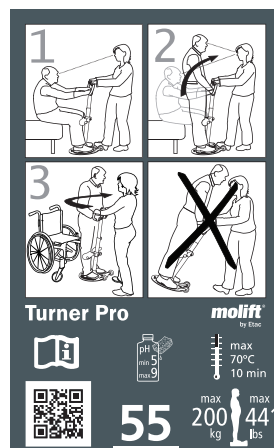

Turner PRO – Utilisation révue

Le Turner PRO est un outil d'aide au transfert et à la verticalisation qui permet au personnel soignant d'aider un patient à se redresser et de le transférer d'une position assise à une autre. En outre, il est conçu pour les patients capables d'assurer une prise et de soulever leur propre poids, mais qui requièrent néanmoins une assistance/de l'aide pour se lever et se déplacer. L'outil est destiné au transfert de patients depuis/vers leur lit, une chaise, un fauteuil roulant ou les toilettes. Conçu à partir de matériaux légers, le Turner PRO peut facilement être déplacé. Le Turner PRO ne doit être utilisé qu'en intérieur sur des surfaces planes.

Turner PRO

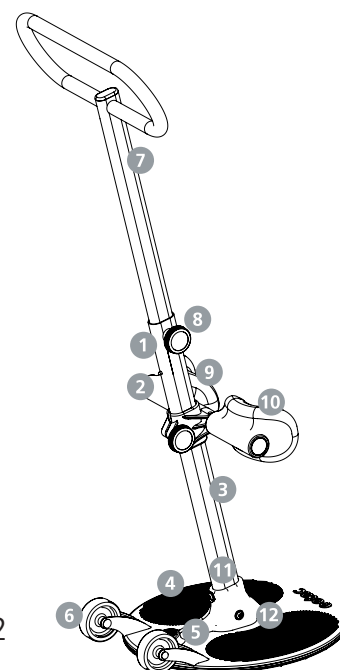

1. Barre extérieure
2. Tige de blocage
3. Marquage de hauteur
4. Plateau principal
5. Repose-pieds pour l'assistant
6. Roulettes
7. Barre intérieure avec poignée
8. Bouton tournant
9. Guide d'utilisation rapide
10. Support de jambes
11. Étiquette du produit
12. Boulons



**Données techniques**

Charge maximale d'utilisation (CMU - SWL, Safe Working Load) :

200 kg (441 lbs)

Poids de l'unité :

8kg

Dimensions :

Hauteur (A) : 0,8 – 1,2 m

Hauteur (B) : 0,3 – 0,55 m

Profondeur (C) : 0,46 m

Largeur (D) : 0,45 m

Repose-pieds (Ø) : 0,40 m

Matériaux :

Aluminium avec revêtement par poudre, plastique, acier

Durée de vie prévue :

La durée de vie prévue du Turner PRO est de 5 ans ou de 15 000 cycles de rotation

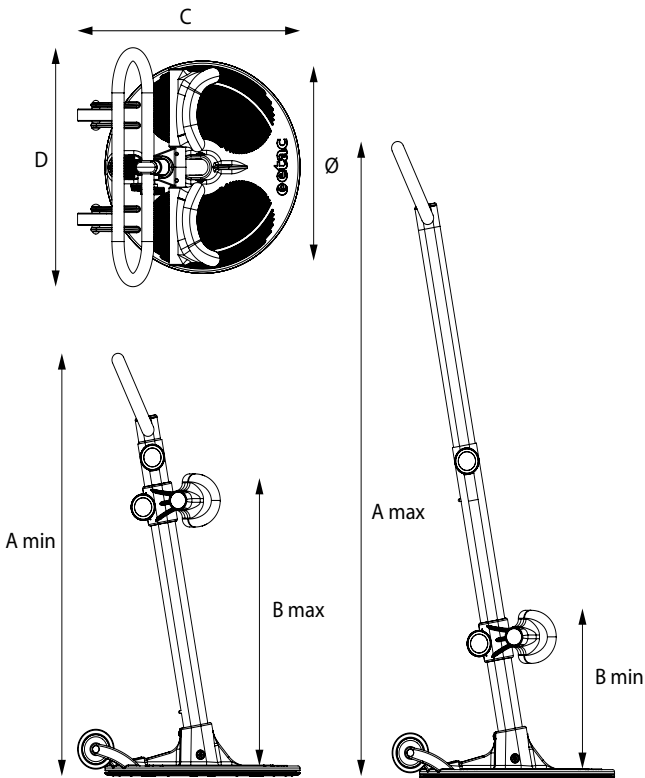

**Montage du support de jambes**

Les repose-genoux peuvent être réglés selon la taille de l'utilisateur. Le support de jambes peut être réglé progressivement de 0,3 à 0,55 mètre. Suivez les trois étapes ci-dessous lorsque vous montez le support de jambes :

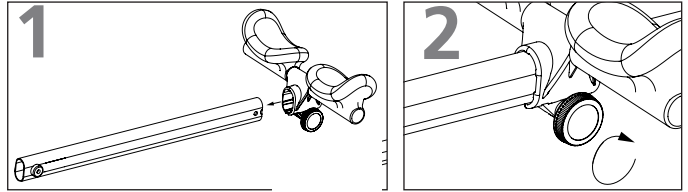

1 Posez la barre sur une surface plane. Insérez le support de jambes de manière à ce que les cale-genoux soient positionnés face vers le haut. Veillez à ce que les deux boutons soient du même côté.

2 Serrez le bouton en le tournant dans le sens des aiguilles d'une montre.

**Assemblage de la barre sur le plateau principal**

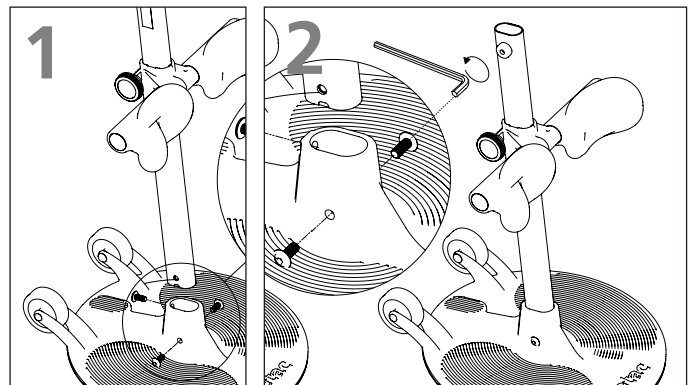

1 Placez le plateau principal sur une surface plane. Insérez la barre de manière à ce que les cale-genoux soient orientés dans la direction opposée par rapport aux roulettes

2 Insérez les trois vis dans les trous du plateau principal. Utilisez la clé Allen pour serrer les boulons. Serrez les boulons fermement.

**⚠ Assurez-vous que les trois boulons sont correctement serrés. Des boulons mal serrés peuvent entraîner une fixation instable de la barre et rendre l'utilisation du Turner PRO dangereuse.**

**Éléments fournis**

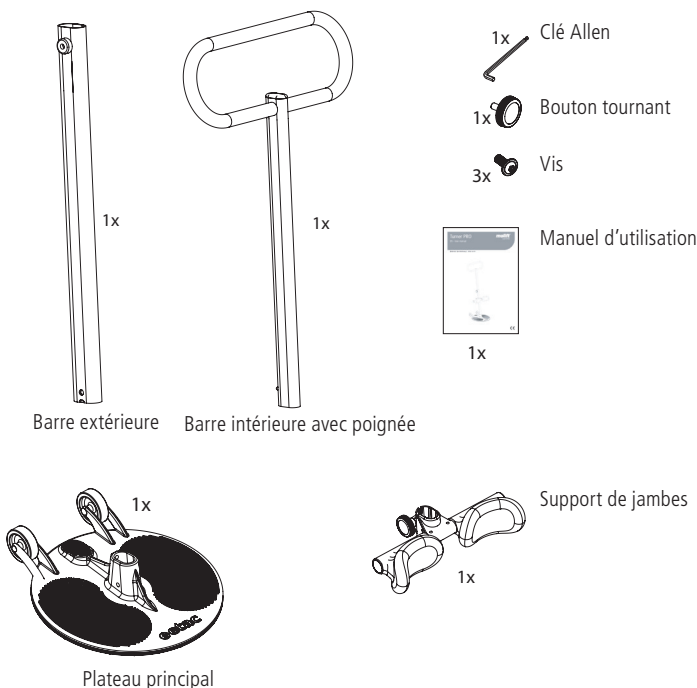

**Montage de la poignée**

La poignée est réglable progressivement de 0,8 à 1,2 mètre. Suivez les trois étapes suivantes lorsque vous montez la poignée :

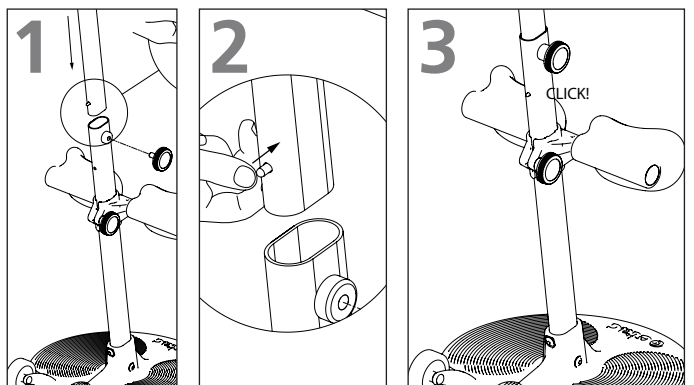

1 Placez la poignée de manière à ce que la tige de blocage soit positionnée en direction des roulettes.

2 Enfoncez la tige de blocage et glissez la barre à l'intérieur de la barre assemblée.

3 Il montaggio è avvenuto correttamente quando si sente un "clic". Ruotare e serrare la manopola.

### Liste de vérification post-montage



Terminez le contrôle indiqué par la liste de vérification post-montage avant de commencer à utiliser le Turner PRO.

Utilisez cette liste de vérification pour vous assurer que le Turner PRO est installé comme il faut et peut fonctionner correctement et en toute sécurité avant toute utilisation. Consultez les données d'assemblage disponibles à la page précédente pour de plus amples informations.

- Veillez à ce que le support de jambes soit monté correctement.
- Vérifiez que les trois boulons disposés entre la barre extérieure et le plateau principal sont montés correctement et bien serrés.
- Contrôlez que la poignée (de la barre intérieure) est montée correctement.
- Assurez-vous que le Turner PRO tourne librement.

### Réglage de la hauteur de la poignée

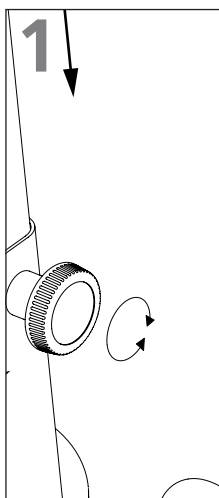

1 Tournez le bouton dans le sens contraire des aiguilles d'une montre et ajustez la hauteur de la poignée.

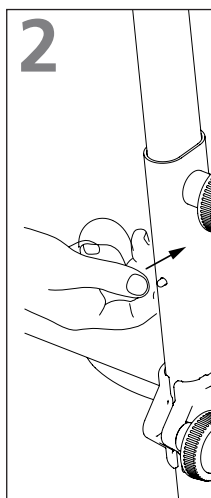

2 Enfoncez la tige de blocage si la poignée est en position haute.

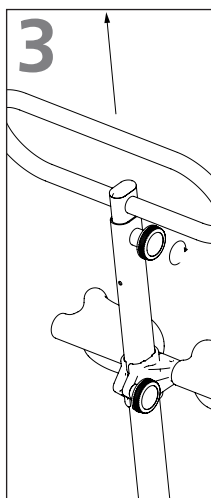

3 Une fois que la poignée se trouve dans la position souhaitée, tournez le bouton dans le sens des aiguilles d'une montre pour verrouiller la position.



Faites preuve de vigilance lors du réglage de la hauteur de la poignée : celle-ci risque de glisser vers le bas et de cogner la tête ou toute autre partie supérieure du corps de la personne effectuant la manipulation.



N'utilisez en aucun cas la poignée si celle-ci se trouve surélevée par rapport à la tige de blocage. Une telle position conduirait à une fixation instable de la barre et rendrait l'utilisation du Turner PRO dangereuse.

### Réglage de la hauteur du support de jambes

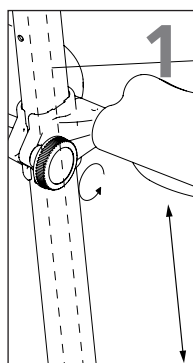

1 Tournez le bouton dans le sens contraire des aiguilles d'une montre et réglez la hauteur des cale-genoux.

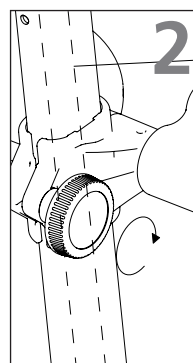

2 Une fois que les cale-genoux se trouvent à la hauteur souhaitée, tournez le bouton dans le sens des aiguilles d'une montre pour verrouiller la position.

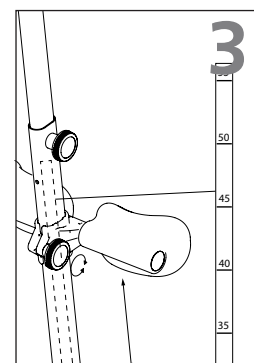

3 Vous pouvez lire la hauteur des cale-genoux sur le marquage de hauteur présent sur la barre. Le numéro se trouvant au-dessus du support de jambes indique la bonne hauteur.



Veillez à ce que les boutons soient correctement serrés. Des boutons mal serrés peuvent entraîner un glissement de la poignée ou du cale-genoux et rendre l'utilisation du Turner PRO dangereuse.

### Positionnement du Turner PRO



1 Commencez par aligner le support de départ avec le nouveau support (chaise, fauteuil roulant, toilette ou lit).

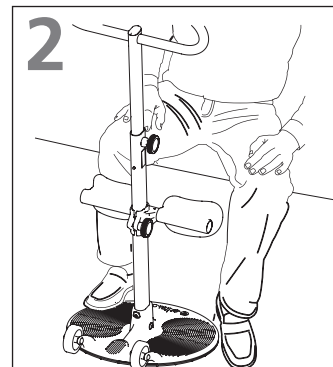

2 Glissez le Turner PRO sous les pieds de l'utilisateur.

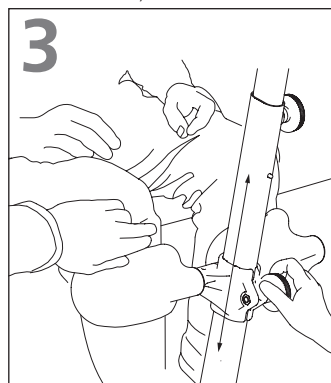

3 Réglez la hauteur du support de jambes de manière à ce qu'il soit positionné deux doigts sous la rotule de l'utilisateur.

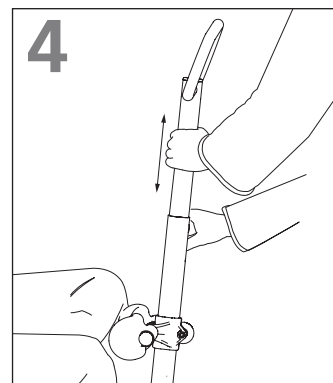

4 Réglez la hauteur de la poignée jusqu'à ce que sa position soit confortable tant pour l'utilisateur que pour l'assistant.

### Transport et stockage

El Turner PRO puede almacenarse y transportarse a temperaturas situadas entre -25 y 70 °C con una humedad relativa de entre el 15 y el 93 %.

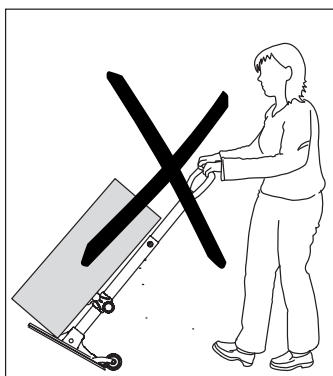

N'utilisez jamais le Turner PRO pour le transport de personnes ou d'objets.

### Transfert de l'utilisateur

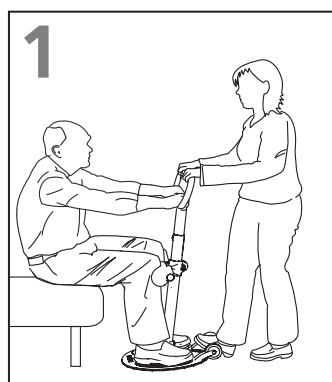

Serrez la poignée à deux mains et placez un pied sur le repose-pieds. L'utilisateur saisit la poignée, avec les deux mains si possible.

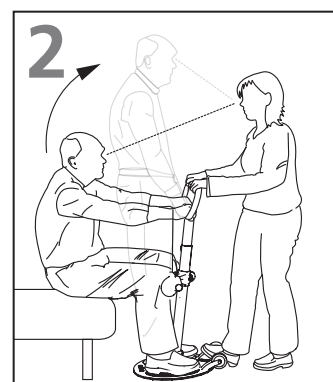

Incitez l'utilisateur à se lever tout en contrebalançant son poids à l'aide d'un pied et de vos deux mains (utilisez votre propre poids en vous penchant vers l'arrière).

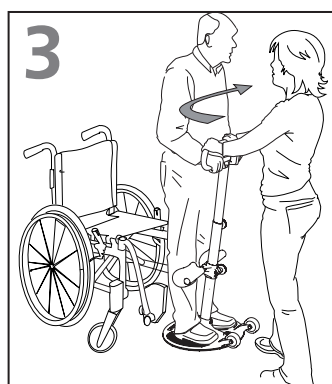

Faites pivoter le Turner PRO afin de transférer le patient à l'avant du nouveau support.



Appuyez sur le repose-pieds tout en prenant fortement appui sur les pieds et demandez à l'utilisateur de s'asseoir. Maintenez le contact oculaire avec l'utilisateur pendant toute la durée du processus de transfert.

### Utilisateur/Assistant

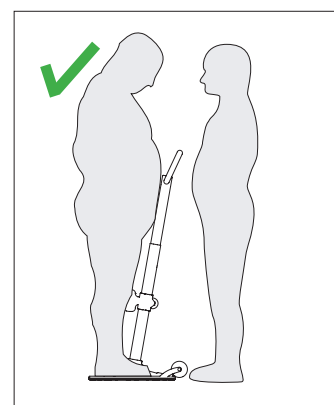
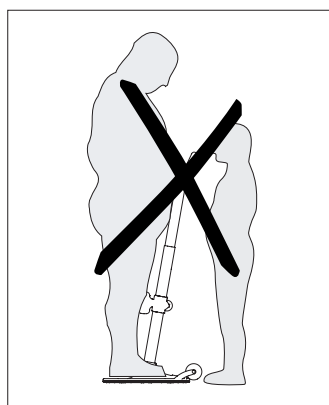

L'assistant doit être en mesure de supporter le poids de l'utilisateur.

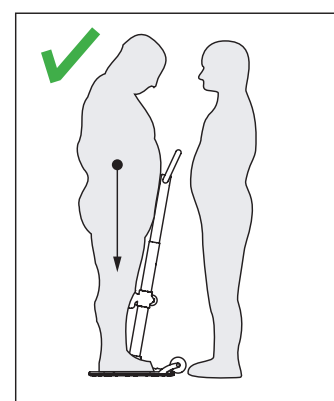
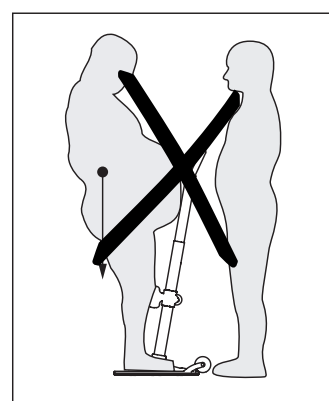

Veillez à ce que le poids de l'utilisateur se situe au niveau du plateau principal

### Nettoyage et désinfection

Nettoyez régulièrement. Nettoyez les surfaces avec un chiffon humide et un détergent approprié au pH neutre. N'utilisez pas de solvants ou de liquides forts, car ils pourraient endommager les surfaces du Turner PRO. Lorsqu'une désinfection est nécessaire, utilisez de l'alcool isopropylique ou un produit similaire. Évitez les produits de nettoyage abrasifs. Retirez les cheveux et les poils de tapis pouvant s'être coincés dans les roulettes et assurez-vous que celles-ci tournent librement.



Assurez-vous de ne pas endommager ou ôter les étiquettes lors du nettoyage.

### Reconditionnement

Respectez les procédures de nettoyage et d'assemblage. Un document séparé relatif au reconditionnement est disponible sur Etac.com.

### Recyclage

Le Turner PRO peut être mis au rebut selon les procédures applicables aux déchets métalliques. Les instructions de recyclage sont disponibles sur Etac.com.

### Pièces détachées

Une liste de pièces détachées est disponible sur Etac.com.

Generale

Dichiarazione di conformità CE



Il prodotto e i relativi accessori descritti nelle presenti istruzioni per l'uso (IFU) sono conformi al regolamento (UE) 2017/745 del 5 aprile 2017 - come dispositivo medico, classe di rischio I. Il prodotto è fabbricato e testato secondo la norma EN 12182:2012 e parti selezionate della norma EN/ISO 10535:2006. Qualsiasi incidente grave che si verifichi in relazione al dispositivo deve essere segnalato al produttore e all'autorità competente dello Stato membro in cui risiede l'utente e/o il paziente.

Condizioni di utilizzo:

Il trasferimento del paziente potrebbe presentare dei rischi. È consentito utilizzare l'attrezzatura descritta nel presente manuale dell'utente esclusivamente a personale in possesso dell'adeguata formazione.

Garanzia

Garanzia di 2 anni per difetti di fabbricazione e dei materiali dei nostri prodotti. Consultare [www.etac.com](http://www.etac.com) per i termini e le condizioni.

Consultare [www.etac.com](http://www.etac.com) per i termini e le condizioni.

Visitare [www.etac.com](http://www.etac.com) per scaricare la versione più recente della documentazione.

Important

Il presente manuale dell'utente contiene importanti istruzioni e informazioni di sicurezza relative all'utilizzo di Turner PRO e dei suoi accessori. Nel presente manuale, per "utente" si intende la persona che viene trasferita. L'assistente è la persona che utilizza Turner PRO.



Questo simbolo indica un'informazione importante relativa alla sicurezza. Seguire attentamente queste istruzioni.



Leggere il manuale dell'utente prima dell'uso. È importante comprendere pienamente il contenuto del manuale dell'utente prima di utilizzare l'attrezzatura.

Modifiche e utilizzo di componenti fabbricati da altri produttori:

Si consiglia di utilizzare solamente componenti e pezzi di ricambio Etac. Se vengono apportate modifiche al prodotto, la dichiarazione di conformità e la garanzia Etac perdono di validità. Etac non è responsabile di eventuali danni o incidenti che possano verificarsi quando si utilizzano componenti di altri produttori.

Valutazione del rischio

Valutare i rischi e prendere appunti.

L'assistente è responsabile della sicurezza dell'utente.



Le operazioni di riparazione sono consentite esclusivamente al personale tecnico

Etichette e simboli

Etichetta del prodotto:

L'etichetta contiene il numero dell'articolo e il numero di serie (codice a barre). Il codice EAN include;

(01) Numero EAN):xxxxxxxx

(11) (Lotto): AAMMGG

(21) (Numero di serie): xxxxx



Breve manuale dell'utente:

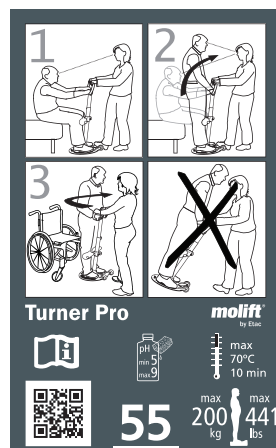

Simboli:

Simboli usati sul prodotto, descritti in maggiore dettaglio:



Produttore



Data di produzione



Numero di catalogo



Numero di serie



Dispositivo medico



Marchio CE



Fare riferimento al manuale dell'utente



Temperatura massima di lavaggio



Peso massimo utente (carico di sicurezza)



pH di lavaggio



QR Code

Turner PRO - uso previsto

Turner Pro è un sostegno di sollevamento e trasferimento che agevola l'assistente nell'aiutare l'utente ad alzarsi e nel trasferirlo in un'altra posizione seduta. Va utilizzato da utenti che possono aggrapparsi e sostenere il peso del proprio corpo, ma che necessitano di assistenza/aiuto per alzarsi ed essere trasferiti. È destinato al trasferimento di un utente da/a letto, sedia, sedia a rotelle o sanitari. Turner PRO è composto da materiali leggeri e può essere facilmente trasferito in una nuova posizione. Turner PRO deve essere usato solamente in interni su superfici piane.

Turner PRO

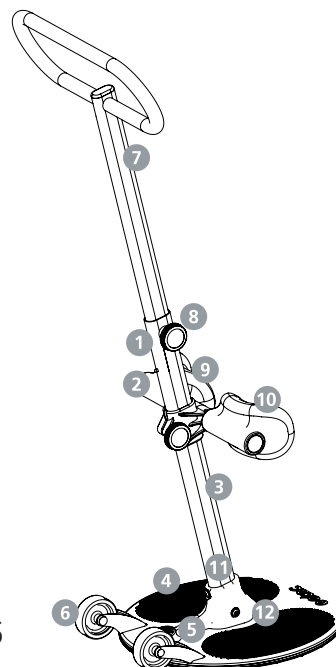

1. Palo esterno
2. Perno di chiusura
3. Altezza dell'etichetta
4. Piattaforma principale
5. Poggiapiedi per l'assistente
6. Ruote di trasporto
7. Palo interno con impugnatura
8. Manopola
9. Breve manuale dell'utente
10. Supporto gambe
11. Etichetta del prodotto
12. Bulloni

**Dati tecnici**

Carico di lavoro sicuro  
(SWL, Safe Working Load):  
200 kg (441 lbs)

Peso dell'unità:  
8kg

Dimensioni:

Altezza (A): 0,8–1,2 m  
Altezza (B): 0,3–0,55 m  
Profondità (C): 0,46 m  
Ampiezza (D): 0,45 m  
Piastra di supporto per piedi (Ø): 0,40 m

Materiale:

Alluminio, plastica, acciaio  
verniciato a polveri

Durata prevista:

Turner PRO ha una durata  
prevista di 5 anni o 15.000  
cicli di rotazione

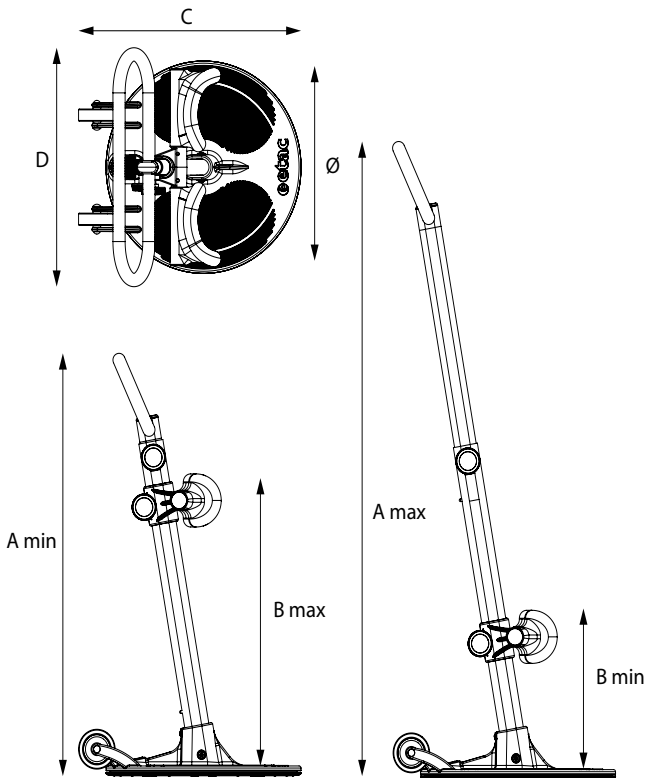

**Componenti in dotazione**

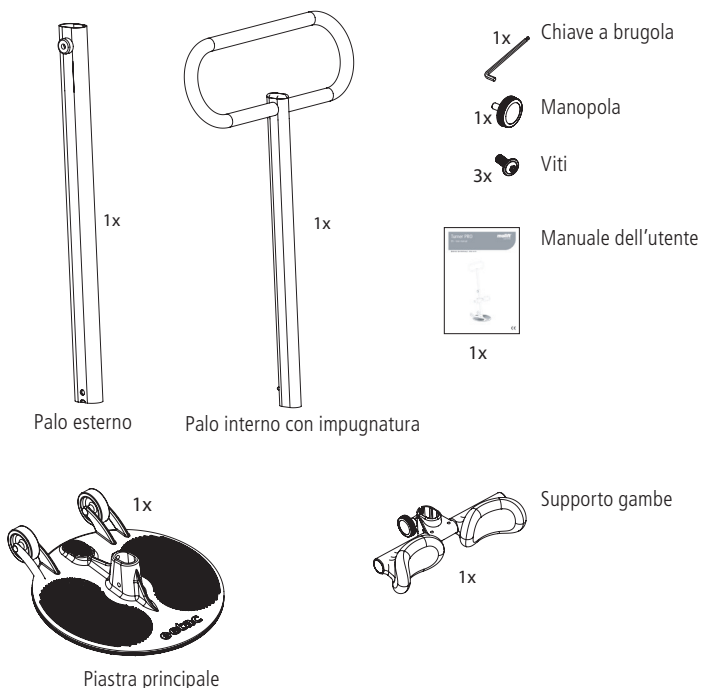

**Montaggio supporto gambe**

I cuscini per le ginocchia possono essere regolati singolarmente. Il supporto gambe consente una regolazione continua da 0,3 a 0,55 metri. Seguire questi tre passaggi per il montaggio del supporto gambe:

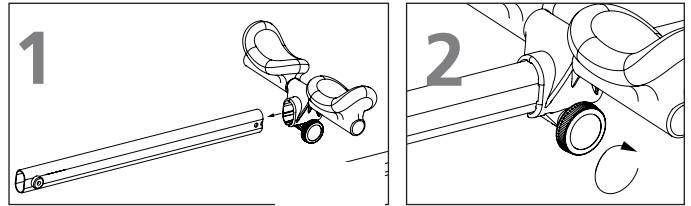

Appoggiare il palo su una superficie piana. Inserire il supporto gambe con le ginocchiere rivolte verso l'alto. Accertarsi che entrambe le manopole siano sullo stesso lato.

Serrare la manopola girandola in senso orario.

**Montare il palo sulla piastra principale**

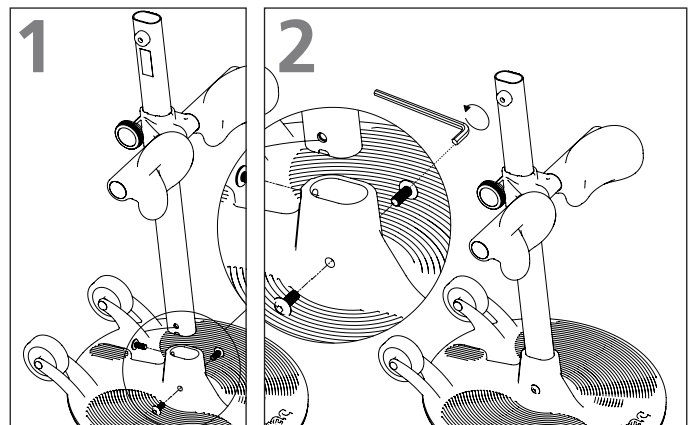

Posizionare la piastra di base su una superficie piana. Inserire il palo con le ginocchiere rivolte in direzione opposta alle ruote.

Inserire le tre viti nei fori presenti sulla piastra di base. Usare la chiave a brugola per avvitare i bulloni. Serrarli saldamente.



**Accertarsi che tutti e tre i bulloni siano ben serrati. In caso contrario, il palo potrebbe essere instabile e l'uso di Turner PRO risulterebbe pericoloso.**

**Montaggio dell'impugnatura**

L'impugnatura consente una regolazione continua da 0,8 a 1,2 metri. Seguire questi tre passaggi per il montaggio dell'impugnatura:

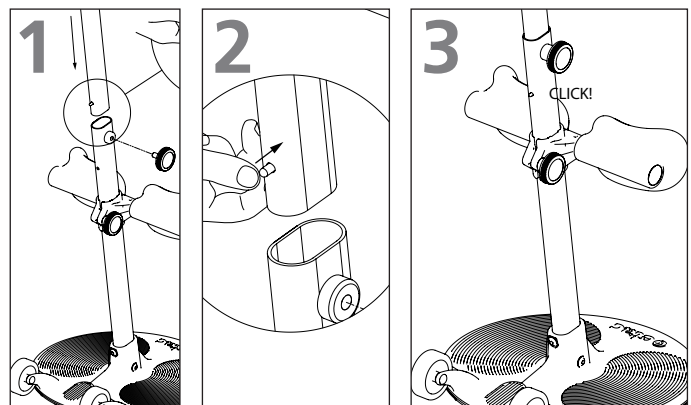

Posizionare l'impugnatura con il perno di chiusura rivolto verso le ruote.

Premere il perno di chiusura e far scorrere il palo nel palo precedentemente montato.

Il montaggio è avvenuto correttamente quando si sente un "clic". Ruotare e serrare la manopola.

### Lista di controllo post-montaggio



**Non iniziare a utilizzare Turner PRO prima di aver completato la verifica secondo la lista di controllo post-montaggio.**

Prima dell'utilizzo, usare la presente lista di controllo per verificare che Turner PRO sia stato installato adeguatamente e accertarsi che funzioni in modo corretto e sicuro. Per maggiori dettagli, consultare le informazioni di montaggio nella pagina precedente.

- Assicurarsi che il supporto gambe sia montato correttamente.
- Assicurarsi che tutti e tre i bulloni tra il palo esterno e la piastra principale siano montati e serrati correttamente.
- Assicurarsi che l'impugnatura (palo interno) sia montata correttamente.
- Assicurarsi che Turner ruoti liberamente.

### Regolazione dell'altezza dell'impugnatura

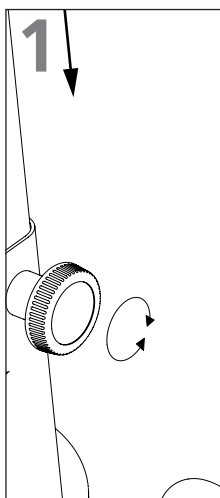

Ruotare la manopola in senso orario e regolare l'altezza dell'impugnatura.

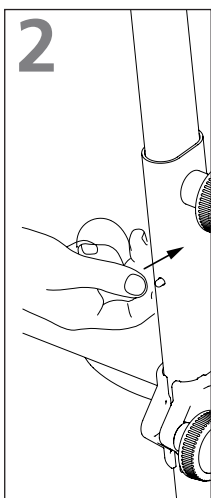

Premere il perno di chiusura verso l'interno se l'impugnatura è in posizione alta.

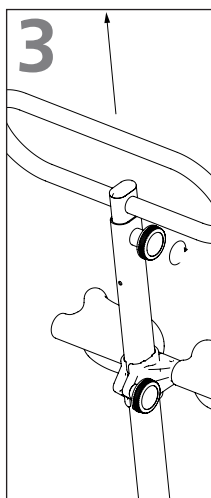

Quando si raggiunge l'altezza dell'impugnatura desiderata, ruotare la manopola in senso orario per bloccarla in posizione.



**Quando si regola l'altezza, prestare attenzione all'impugnatura, in quanto può scivolare e colpire gli operatori sulla testa o sulla parte superiore del corpo.**



**Non usare l'impugnatura se è in posizione più elevata rispetto al perno di chiusura. Ciò potrebbe rendere il palo instabile e l'uso di Turner PRO risulterebbe pericoloso.**

### Regolazione dell'altezza del supporto gambe

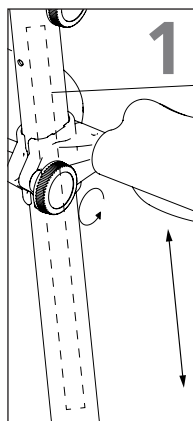

Ruotare la manopola in senso orario e regolare l'altezza del supporto ginocchia.

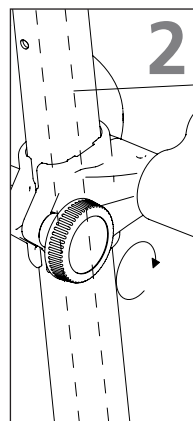

Quando si raggiunge l'altezza del supporto desiderata, ruotare la manopola in senso orario per bloccarlo in posizione.

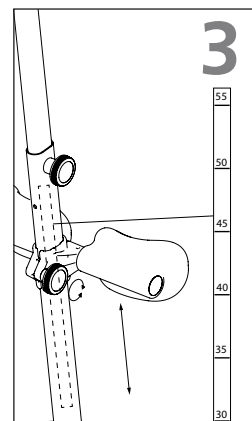

L'altezza del supporto ginocchia può essere verificata usando il metro presente sul palo. Il numero al di sopra del supporto gambe indica l'altezza corretta.



**Accertarsi che i bulloni siano serrati in maniera sicura. In caso contrario, l'impugnatura o il supporto ginocchia potrebbero scivolare e l'uso di Turner PRO risulterebbe pericoloso.**

### Posizionamento di Turner PRO



Allineare la nuova seduta (sedia, sedia a rotelle, sanitari o letto) alla seduta esistente.

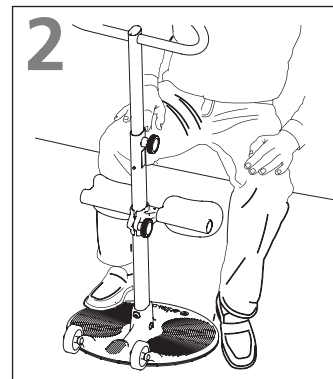

Far scivolare Turner PRO sotto ai piedi dell'utente.

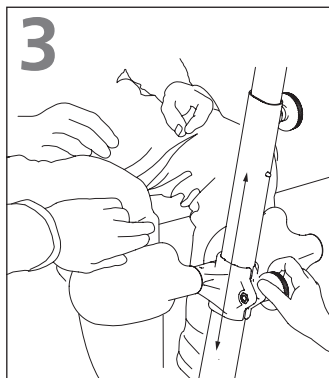

Regolare l'altezza del supporto gambe in modo tale che sia collocato due dita sotto la ginocchia.

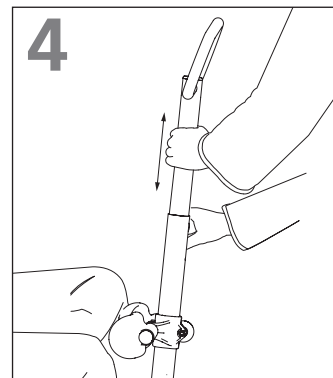

Regolare l'altezza dell'impugnatura in una posizione comoda per utente e assistente.

### Transport and storage Trasporto e conservazione

Turner PRO può essere conservato e trasportato a temperature comprese tra -25 °C e 70 °C con umidità relativa compresa tra il 15% e il 93%.

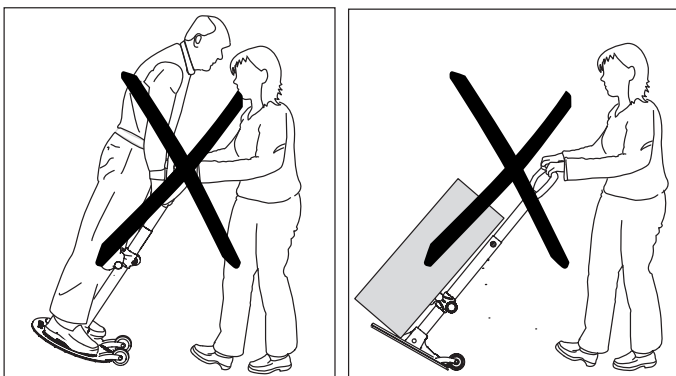

Non utilizzare Turner Pro per il trasporto di persone o oggetti.

### Trasferimento dell'utente

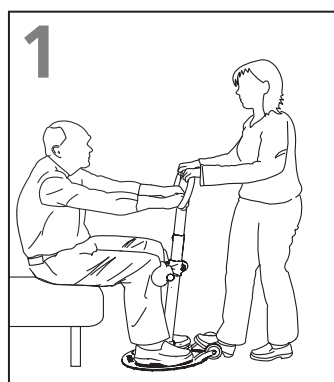

**1**  
Afferrare l'impugnatura con entrambe le mani e posizionare un piede sul poggiapiedi. L'utente afferra l'impugnatura, se possibile con entrambe le mani.

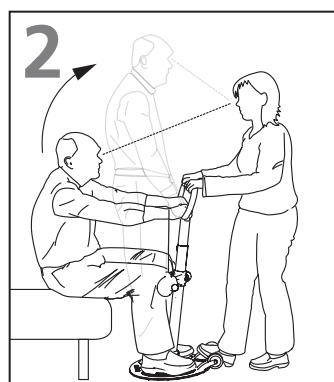

**2**  
Incoraggiare l'utente ad alzarsi e, allo stesso tempo, controbilanciarne il peso con i propri mani e piedi (usare il peso del proprio corpo inclinandosi all'indietro).

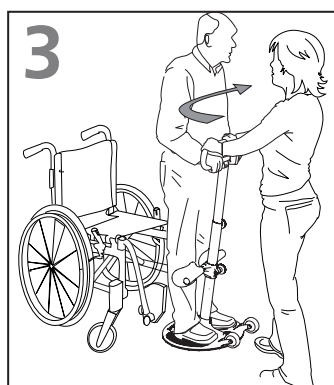

**3**  
Girare Turner PRO in modo tale che l'utente venga trasferito davanti alla nuova seduta.

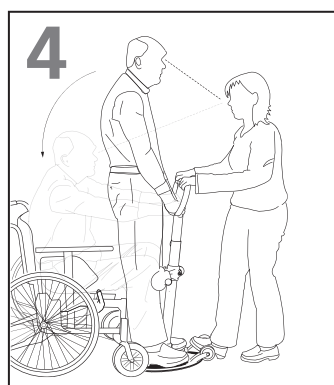

**4**  
Mettere i piedi sul poggiapiedi, caricarvi il peso del proprio corpo e chiedere all'utente di sedersi. Mantenere il contatto visivo con l'utente per l'intero processo di trasporto.

### Utente/Assistente

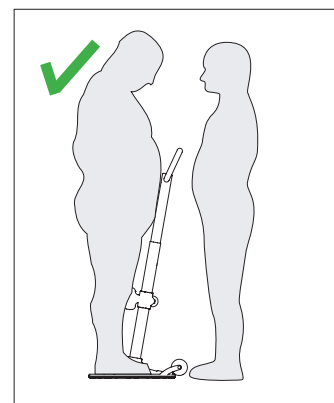
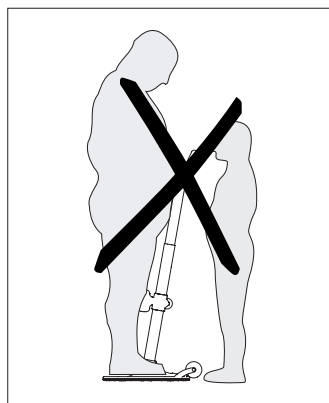

L'assistente deve essere in grado di sostenere il peso dell'utente.

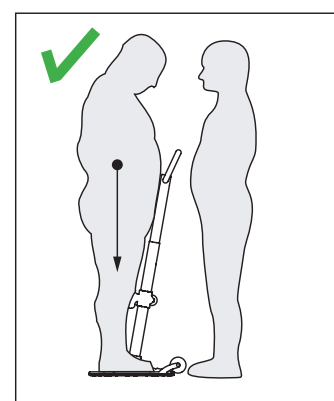
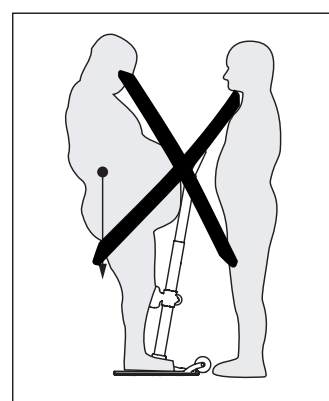

Assicurarsi che il peso dell'utente rientri nella piastra di base.

### Cleaning and disinfection Pulizia e disinfezione

Effettuare la pulizia regolarmente. Pulire le superfici con un panno umido utilizzando un apposito detergente con pH neutro. Non utilizzare solventi o detersivi aggressivi, che potrebbero danneggiare le superfici di Turner. Per la disinfezione, quando necessario: usare alcool isopropilico o simili. Evitare l'impiego di prodotti di pulizia abrasivi. Rimuovere capelli e pelucchi dalle ruote e accertarsi che ruotino liberamente.



Accertarsi di non danneggiare o rimuovere le etichette durante la pulizia.

### Rimessa in servizio

Seguire la procedura di pulizia e montaggio. Un documento separato sulla rimessa in servizio è disponibile su Etac.com.

### Riciclaggio

Turner PRO può essere smaltito come rifiuto metallico. Le istruzioni per il riciclaggio sono disponibili su Etac.com

### Ricambi

Un elenco dei ricambi è disponibile su Etac.com.

General



**Declaración CE**  
 El producto y sus accesorios relacionados, descritos en estas instrucciones de uso (IDU), cumplen con el reglamento (UE) 2017/745 del 5 de abril de 2017 como producto sanitario, clase de riesgo I.  
 El producto se ha fabricado y probado según EN 12182:2012 y algunas partes de EN/ISO 10535:2006.  
 Cualquier incidente grave que se produzca en relación con el dispositivo debe notificarse al fabricante y a la autoridad competente del Estado miembro en el que esté establecido el usuario y/o el paciente.

Condiciones de uso:

Trasladar a una persona puede suponer un elemento de riesgo. El equipo descrito en este manual solamente debe ser utilizado por personal formado.

Aviso de garantía:

Garantía de 2 años contra defectos de mano de obra y en materiales de nuestros productos.  
 Consulte los términos y condiciones en [www.etac.com](http://www.etac.com).

Visite [www.etac.com](http://www.etac.com) para descargar la versión más reciente de nuestra documentación.

Importante

Este manual de usuario contiene instrucciones de seguridad importantes e información relacionada con el uso del Turner PRO y sus accesorios. En este manual, por «usuario» se entiende la persona que es trasladada. El «asistente» es la persona que maneja el Turner PRO



Este símbolo indica que se trata de información importante sobre seguridad. Siga atentamente estas instrucciones.



¡Lea el manual de usuario antes de su uso!  
 Es importante entender completamente el contenido del manual de usuario antes de utilizar el equipo.

Modificaciones y uso de piezas de otros fabricantes:

Recomendamos usar exclusivamente componentes y recambios de Etac. Si se modifica el producto, la declaración de conformidad deja de ser válida y Etac no se hace responsable de la garantía. Etac no se hace responsable de los errores o accidentes que puedan producirse al usar componentes de otros fabricantes.

Evaluación de riesgos

Evalúe el riesgo y tome nota de él.

¡El asistente es responsable de la seguridad del usuario!



Solamente el personal técnico está autorizado a realizar reparaciones.

Símbolos y etiquetas

Etiqueta del producto:

La etiqueta contiene el número de referencia y el número de serie (códigos de barras) El código EAN contiene:

(01) (n.º EAN): xxxxxxxxxx

(11) (Lote): AAMMDD

(21) (Número de serie): xxxxx



Símbolos:

Explicación más detallada de los símbolos utilizados en el producto:



Fabricante



Fecha de fabricación



Número de catálogo



Número de serie



Producto sanitario



Con marcado CE



Consulte el manual de usuario



Temperatura máxima en el lavado



Peso máximo del usuario (SWL)



pH en el lavado



Código QR

Guía de utilización breve:

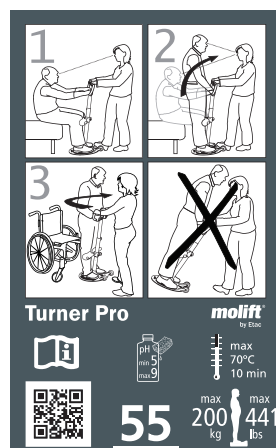

Turner PRO: uso previsto

El Turner PRO es un soporte de transferencia y levantamiento de usuarios que permite al cuidador ponerlo de pie y cambiarlo a otra posición sentada. Este dispositivo está indicado para usuarios que pueden agarrarse y levantar todo el peso de su cuerpo, pero que requieren ayuda/apoyo para mantenerse de pie y moverse. Está pensado para trasladar personas desde y hacia la cama, sillas, sillas de ruedas e inodoros. El Turner PRO está fabricado con materiales ligeros y puede desplazarse fácilmente a otras ubicaciones. El Turner PRO solo está indicado para su uso en interiores y sobre superficies planas.

Turner PRO

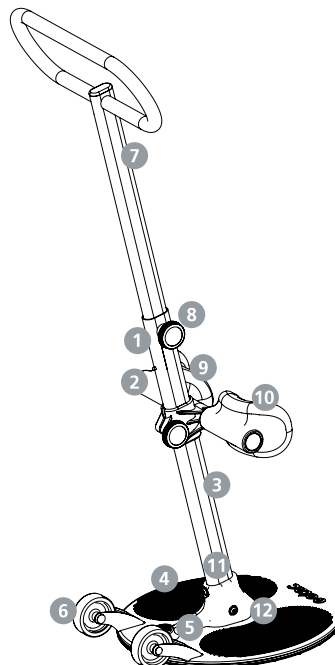

1. Poste exterior
2. Pasador de bloqueo
3. Etiqueta de altura
4. Placa principal
5. Reposapiés para el asistente
6. Ruedas de transporte
7. Poste interior con asa
8. Botón giratorio
9. Guía de utilización breve
10. Soporte de la extremidad
11. Etiqueta del producto
12. Pernos



**Datos técnicos**

**Carga de trabajo segura (SWL, Safe Working Load):**

200 kg (441 lbs)

**Peso de la unidad:**

8kg

**Dimensiones:**

Altura (A): 0,8-1,2 m

Altura (B): 0,3-0,55 m

Profundidad (C): 0,46 m

Anchura (D): 0,45 m

Reposapiés (Ø): 0,40 m

**Material:**

Aluminio recubierto de pintura, plástico y acero.

**Vida útil prevista**

El Turner PRO tiene una vida útil prevista de 5 años u 15000 ciclos de giro

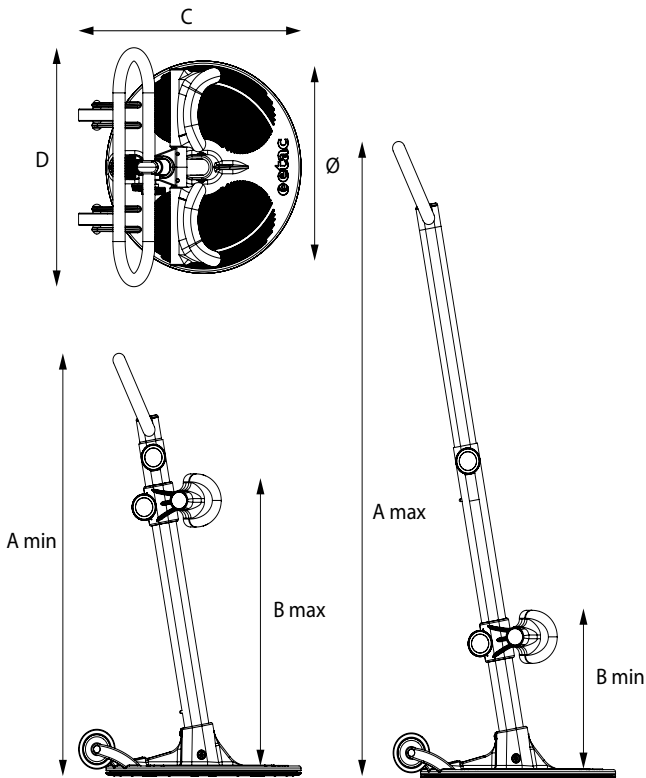

**Montaje del soporte de la extremidad**

El cojín de rodilla puede ajustarse en función del usuario. El soporte de la extremidad puede ajustarse de forma progresiva entre 0,3 y 0,55 metros. Siga estos tres pasos para montar el soporte de la extremidad:

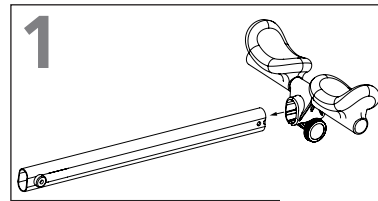

Ponga el poste en el suelo sobre una superficie plana. Inserte el soporte de la extremidad con las almohadillas para las rodillas mirando hacia arriba. Cerciérese de que los dos botones estén en el mismo lado.

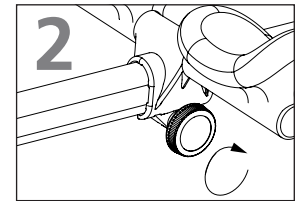

Apriete el botón girándolo en el sentido de las agujas del reloj.

**Montaje del poste en la placa principal**

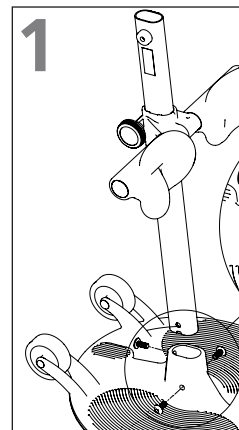

Coloque la placa de apoyo sobre una superficie plana. Inserte el poste con las almohadillas para las rodillas mirando hacia el lado contrario a las ruedas.

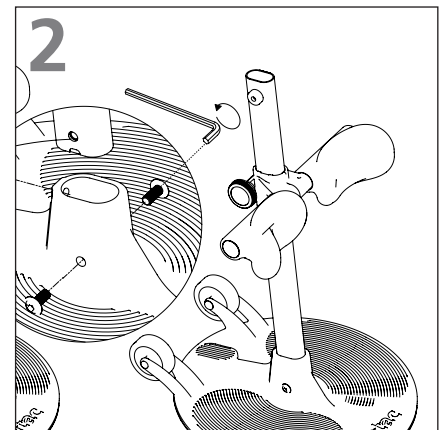

Inserte los tres tornillos en los orificios de la placa de apoyo. Utilice la llave Allen para apretar los pernos. Apriete bien los pernos.

**Asegúrese de que los tres pernos estén correctamente fijados. Si están flojos, el poste podría tambalearse y sería peligroso utilizar el Turner PRO.**

**Piezas suministradas**

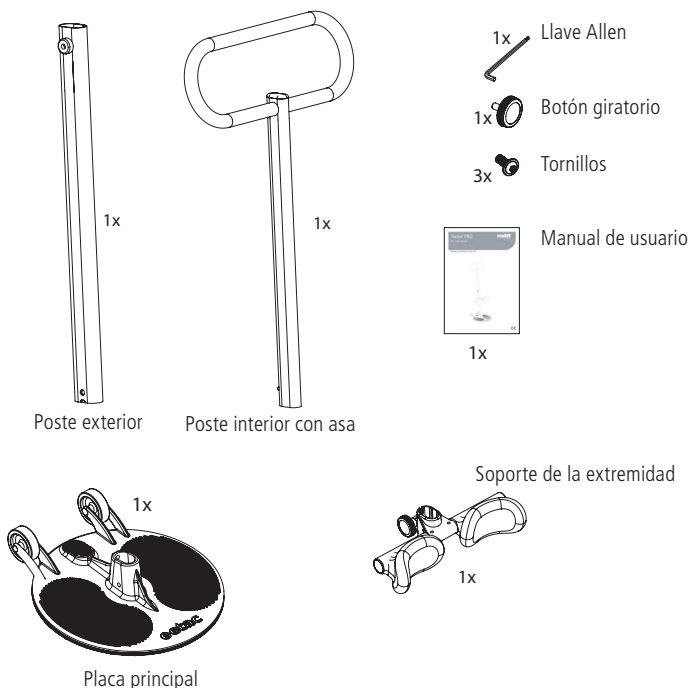

**Montaje del asa**

El asa puede ajustarse de forma progresiva entre 0,8 y 1,2 metros. Siga estos tres pasos para montar el asa:

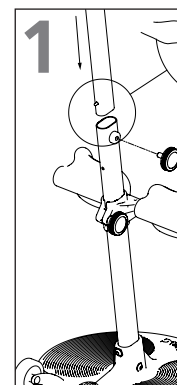

Ponga el asa con el pasador de bloqueo mirando hacia las ruedas

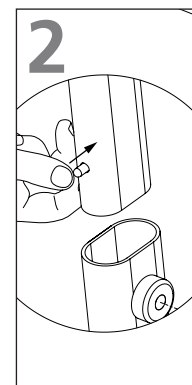

Presione el pasador de bloqueo para que encaje y deslice el poste en el interior del poste ya montado.

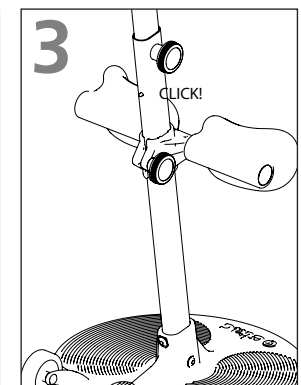

Cuando se oiga un clic, estará montado correctamente. Gire y apriete el botón..

### Lista de comprobación después del montaje



**No empiece a utilizar el Turner PRO sin haber repasado la lista de comprobación tras su montaje.**

Utilice esta lista de comprobación para verificar que el Turner PRO está instalado y funciona de forma correcta y segura antes de su uso. Consulte la información de montaje de la página anterior para ver los detalles.

- Asegúrese de que el soporte de extremidad esté bien montado.
- Compruebe que los tres pernos situados entre el poste exterior y la placa principal estén montados correctamente y bien apretados.
- Asegúrese de que el asa (poste interior) esté bien montada.
- Compruebe que el Turner gire sin problemas.

### Ajuste de la altura del asa

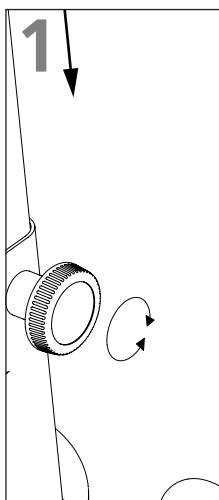

1 Gire el botón en el sentido contrario a las agujas del reloj y ajuste la altura del asa.

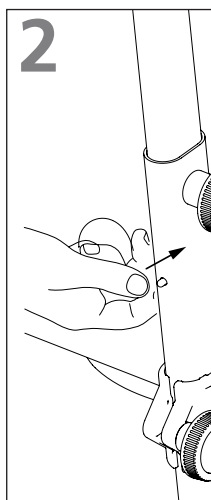

2 Empuje el pasador de bloqueo hacia dentro si el asa está en la posición superior.

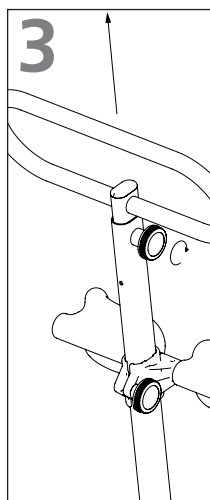

3 Cuando se alcance la altura correcta del asa, gire el botón en el sentido de las agujas del reloj para bloquear la posición.



**Tenga en cuenta el asa al ajustar la altura: puede deslizarse hacia abajo y golpear al operario en la cabeza o en la parte superior del cuerpo.**



**No utilice el asa en una posición superior a la del pasador de bloqueo, puesto que de lo contrario el poste se tambaleará y será peligroso utilizar el Turner.**

### Ajuste de la altura de soporte de la extremidad

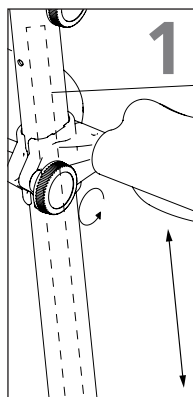

1 Gire el botón en el sentido contrario a las agujas del reloj y ajuste la altura del soporte para las rodillas.

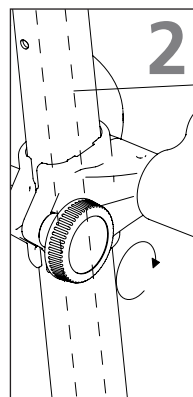

2 Cuando se alcance la altura correcta del soporte para las rodillas, gire el botón en el sentido de las agujas del reloj para bloquear la posición.

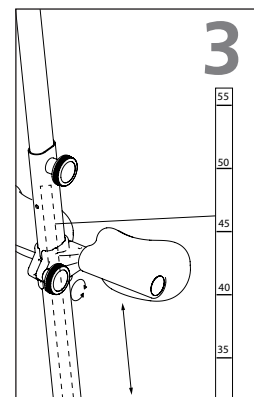

3 La altura del soporte para las rodillas puede leerse en la escala del poste. El número que figura encima del soporte de la extremidad indica la altura correcta.



**Asegúrese de que los botones estén bien apretados. Si están sueltos, el asa o el soporte para las rodillas pueden deslizarse hacia abajo y será peligroso utilizar el Turner**

### Colocación del Turner PRO



1 Coloque el nuevo asiento (silla, silla de ruedas, inodoro o cama) al lado del asiento existente.

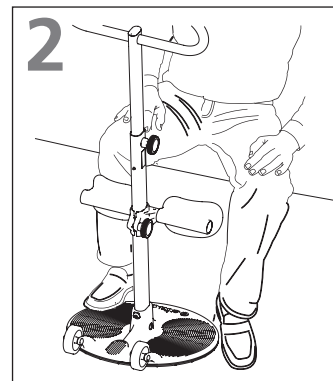

2 Pase el Turner PRO por debajo de los pies del usuario.

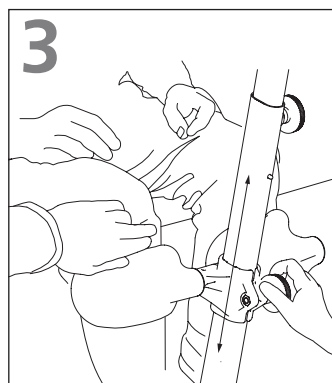

3 Ajuste la altura del soporte de la extremidad de tal modo que quede dos dedos por debajo de la rótula del usuario.

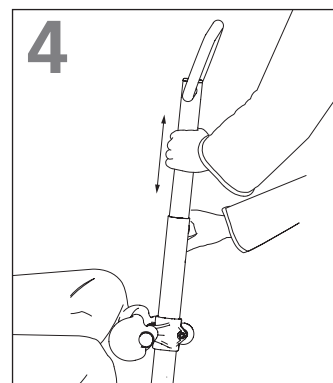

4 Ajuste la altura del asa a una posición que resulte cómoda para el usuario y el asistente.

**Transporte y almacenamiento**

El Turner PRO puede almacenarse y transportarse a temperaturas situadas entre -25 y 70 °C con una humedad relativa de entre el 15 y el 93 %.

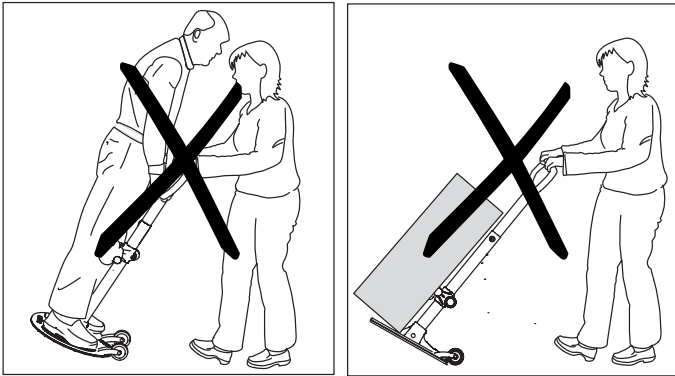

 **No utilice el Turner PRO para transportar personas ni objetos.**

**Traslado del usuario**

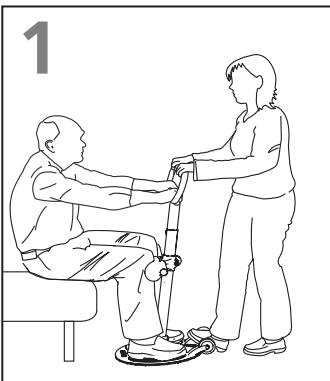

1  
Agarre el asa con ambas manos y coloque un pie en el reposapiés. El usuario agarra el asa, si es posible, con las dos manos.

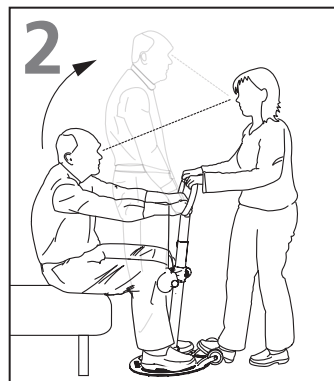

2  
Ayude al usuario a ponerse de pie y, al mismo tiempo, equilibre el peso del usuario con un pie y las manos (utilice su peso corporal inclinándose hacia atrás).

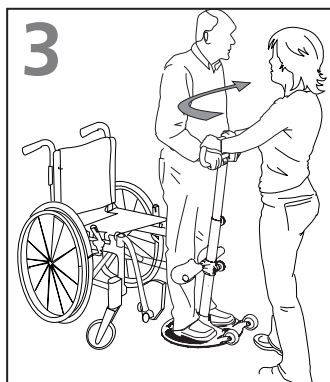



3  
Gire el Turner PRO para que el usuario se transfiera a la parte delantera del nuevo asiento.



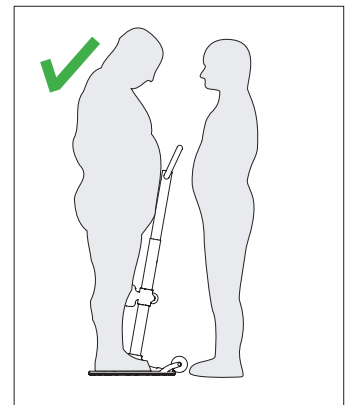
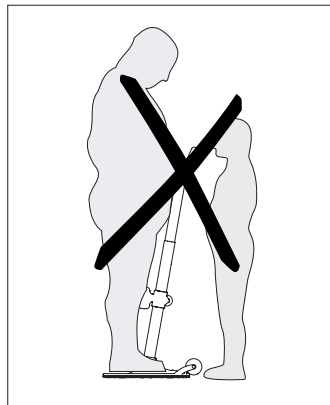

4  
Pise el reposapiés, apóyese con su peso y pida al usuario que se siente. Mantenga el contacto visual con el usuario durante todo el proceso de traslado.

**Usuario/asistente**

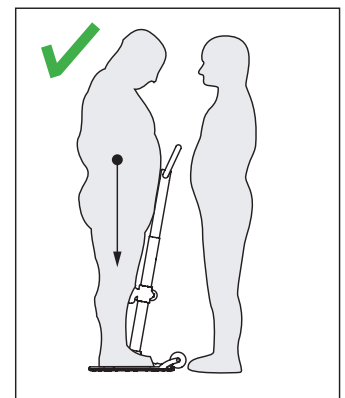
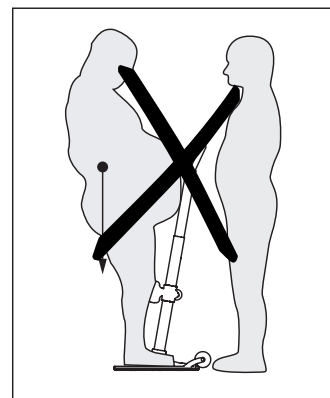

 **El asistente debe poder soportar el peso del usuario.**



 **Asegúrese de que el peso del usuario esté dentro de lo indicado en la placa de apoyo.**

**Limpieza y desinfección**

Limpie el Turner PRO con regularidad. Limpie las superficies con un paño húmedo utilizando un detergente con pH neutro adecuado. No utilice disolventes ni líquidos fuertes, pues podría dañar las superficies del Turner. Cuando sea necesario desinfectar, utilice alcohol isopropílico o similar. Evite utilizar productos de limpieza abrasivos. Retire las posibles pelusas y pelos de las ruedas y compruebe que giren sin problemas.

 **Asegúrese de que las etiquetas no se hayan dañado ni eliminado con la limpieza.**

**Ajustes**

Siga el procedimiento de limpieza y montaje. La documentación específica de los ajustes está disponible en Etac.com.

**Reciclaje**

El Turner PRO puede desecharse como residuo metálico. Las instrucciones para el reciclaje se proporcionan en Etac.com.

**Piezas de recambio**

Hay una lista de piezas de recambio disponible en Etac.com.



Etac A/S  
Parallevej 3  
DK-8751 Gedved  
[www.etac.com](http://www.etac.com)

***molift***<sup>®</sup>  
by Etac