

FITTING INSTRUCTIONS

SELECTING THE CORRECT SIZE

1

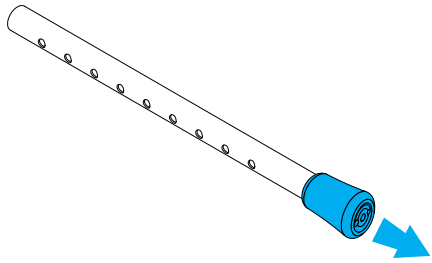

2

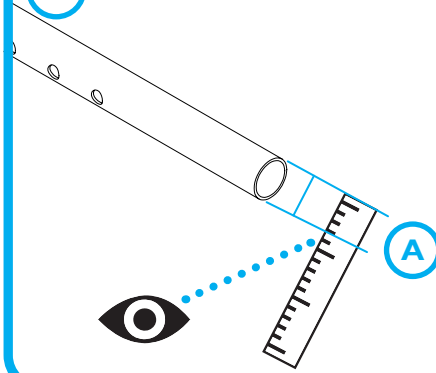

i

TUBE MEASURING GUIDE (TO SCALE ON A4 PAGE)

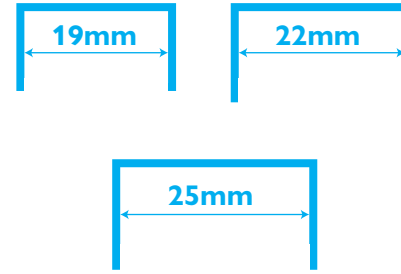

3

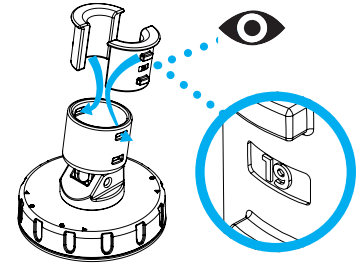

IF A = 19MM USE 2X 19MM INSERT
IF A = 22MM USE 2X 22MM INSERT
IF A = 25MM USE 2X 25MM INSERT

*IF LEG FIT IS LOOSE, INSERTS CAN BE MIXED AND MATCHED AS REQUIRED.

FITTING TO A FRAME

i ANGLE OPTIONS

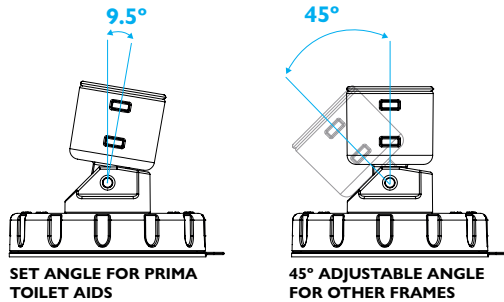

1

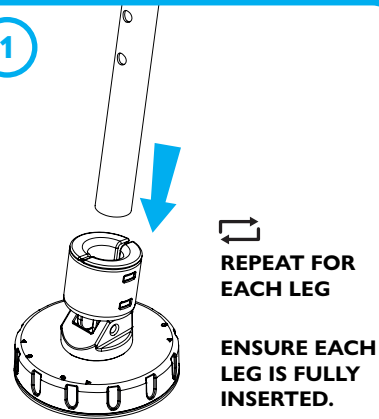

2

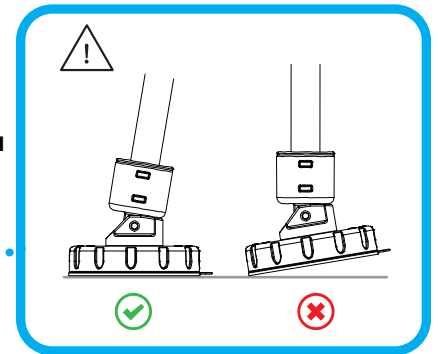
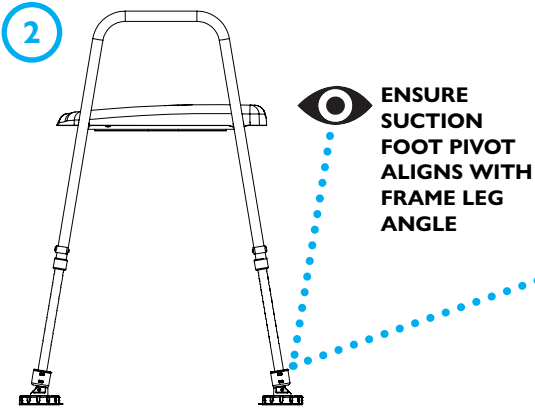

ACTIVATING THE SUCTION

i 

ENSURE SURFACES ARE FLAT, SMOOTH, CLEAN AND DRY

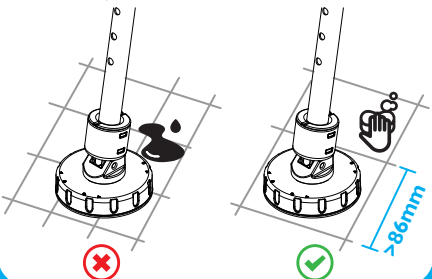

2

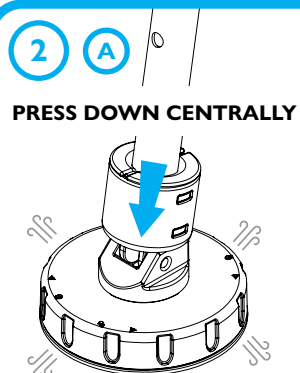

B 

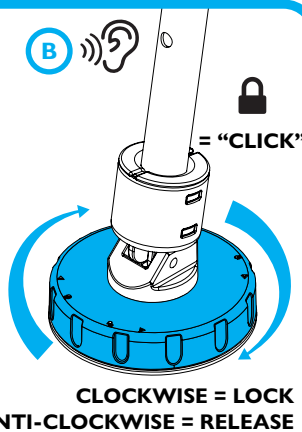

3

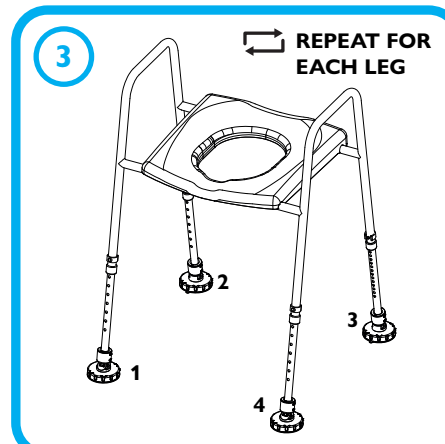

4

