

Homecraft™ Deluxe Mobile Shower Commodes

Owner's Manual



Intended Uses

The Homecraft Deluxe Mobile Shower Commode Chairs have been specifically designed to alleviate and compensate for illness, injury or impairment that leads to functional problems with a vital body function. The chair's main function is to allow safe and dignified transportation for those with a disability or physical impairment to get to either a shower or toilet, providing support and mobility for the user and/or carer. Thus addressing the needs of individuals with long term health conditions, such as but not limited to osteo arthritis, multiple sclerosis, spinal cord injury, brain injury and cerebral palsy.

Each chair features specific functions, such as:

- An aperture seat allowing the chair to be used over the toilet or as a commode and providing access for personal cleansing.
- The armrests that can be lifted up for access and side transfers. The armrests act as a support providing stability and safety for the user, reducing the possibility of the user falling.
- The handle at the rear of the frame allows the user to be pushed to and from the bathroom/toilet by a carer.
- The footrests that support the user during transportation and usage, can also be lifted into the upright position when not in use allowing safe access.
- Backrest to provide support and stability for the user.
- Lockable castors that retain the chair in position whilst transferring the user and while the chair is in use in the shower or over the toilet.

BEFORE USING THE HOMECRAFT DELUXE SHOWER COMMODE CHAIR, IT IS ESSENTIAL THAT YOU READ AND FULLY FAMILIARISE YOURSELF WITH THE INSTRUCTIONS BEFORE USE. A FULL RISK ASSESSMENT SHOULD BE CARRIED OUT BEFORE USE OF THE PATIENT AND CHAIR TO ENSURE BOTH ARE SUITABLE.

Models

CODES	DESCRIPTION	MAX USER WEIGHT
841	18" Seat Width Fixed Height Self Propelled	130kg / 20¼st
842	18" Seat Width Fixed Height Attendant	130kg / 20¼st
09 156 3444	18" Seat Width Height Adjustable Self Propelled	130kg / 20¼st
09 156 3451	18" Seat Width Height Adjustable Attendant	130kg / 20¼st
09 156 3485	20" Seat Width Height Adjustable Heavy Duty Self Propelled	150kg / 23½st
09 156 3469	20" Seat Width Height Adjustable Heavy Duty Attendant	150kg / 23½st
09 156 3477	22" Seat Width Height Adjustable Extra Wide Attendant	200kg / 31¼st
09 156 3493	22" Seat Width Height Adjustable Extra Wide Self Propelled	200kg / 31¼st
09 156 3501	18" Seat Width Height Adjustable Tilt-in-Space	130kg / 20¼st



⚠ CAUTIONS

- Ensure you read the instructions before use.
- Designed for single occupancy only.
- Ensure that the specified maximum user weight is not exceeded. Please see chart on page 1 for the maximum user weight for each shower commode chair.
- Under no circumstances should you stand on the shower commode chair.
- Under no circumstances should you stand on the footplates when entering or exiting the chair as this will tip the chair forwards.
- Remember in a shower environment the floors are wet and slippery. Be aware that if the user leans too far forward in the chair and takes the weight off the rear wheels the chair could slide backwards even with the brakes applied.
- Do not sit on the front edge of the seat as this will also tend to tip the chair forward.
- Maintain an upright posture and lean against the backrest.
- Ensure that all castors and wheels are positioned at the same height.
- Ensure the chairs are only used on level ground.
- When the chairs are stationary, please ensure the brakes are applied.
- Before moving the chairs, ensure the brakes have been released.
- Daily, before use, check the effective operation of the brakes, castors and wheels.
- Regular checks of the shower commode chairs should be made to maintain safety and show the chairs are in good condition for use.
- Regular checks of the castors and wheels are required to ensure these are properly secured to the chairs.
- The chairs should be checked on a regular basis for damage or wear and tear – this includes flaking or cracking paint. Any signs of damage should be noted and reported to the supplier immediately. Should damage be evident, please refrain from using the chair until advice has been provided by the supplier.

ENSURE EXTRA CARE IS ALWAYS TAKEN WHEN ENTERING AND EXITING THE CHAIR.

Instructions for Assembly

1. Remove all parts from the packaging.
2. Insert the backrest into the base tubes at the rear of the chairs and secure in place by tightening up the hand knobs **(see Fig.1)**.



(Fig. 1)

3. Attach the footrest by placing the top bracket in to the base tube at the top of the frame, ensuring the footrest is swung back. Swing the footrest towards the front of the chair until it locks in position, a click sound should be heard. Repeat the same process for the other footrest **(see Fig.2)**.



(Fig. 2)

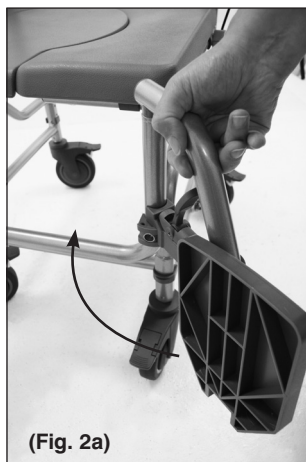

(Fig. 2a)



(Fig. 2b)

4. **ATTENDANT** - Insert the castor stem into the underside of the frame and insert the e-clips at the desired height for the user. (see Fig.3).

PLEASE NOTE there are only three different height settings, do not set the castors to the highest setting which is indicated with a cross below. For further information see 'height adjustment operation' (see Fig.14c)

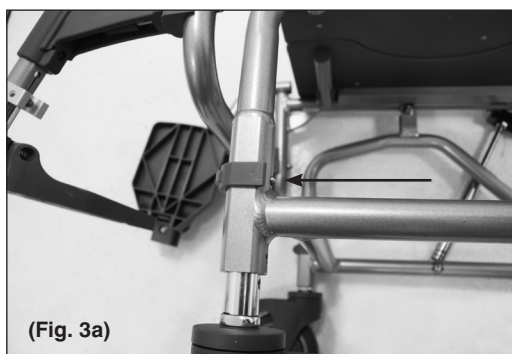
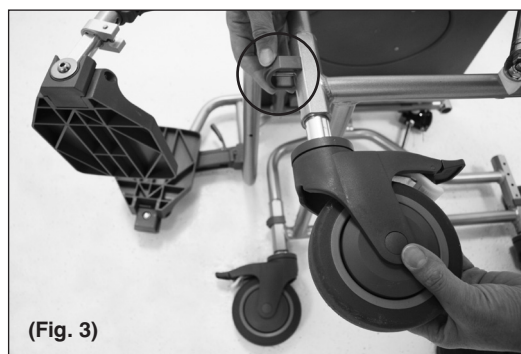

ENSURE THAT THE E-CLIP IS INSERTED FULLY.

5. **SELF-PROPELLED** - Insert the castor stem into the underside of the frame and insert the e-clips (see Fig.3). For the 24" rear wheels, insert the 4.5" bolts through the wheel and the axle bracket at the rear of the chair and apply the nut. Tighten the bolt until the wheel is secure. Place wheel cap over the end of the bolt for protection (see Fig.4).

ENSURE THAT ALL CASTORS AND WHEELS ARE POSITIONED AT THE SAME HEIGHT AND LEVEL ON THE GROUND.



(Fig. 4)

Footrest Operation

1. To adjust the footplate to the required height, loosen the height adjustment screw from the clamp with the Allen key provided. Adjust the footplate to the required height and refit the screw and tighten until secure (see Fig.5).



(Fig. 5)

2. To adjust the footplate angle to the required position, loosen the screw located at the side of the footplate and adjust to the required angle. Tighten the screw until secure (see Fig.6).

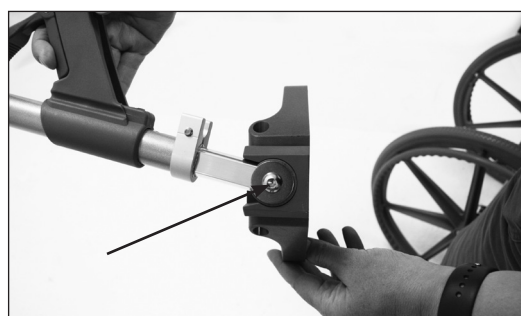

(Fig. 6)

3. To remove the footrests, press the grey lever and rotate the footrest in an outwards direction (see Fig.7).



(Fig. 7)

Armrest Operation

The armrests can be lifted upright for side transfer. Lift the front of the armrest to lift up and push down for lowering (see Fig.8).

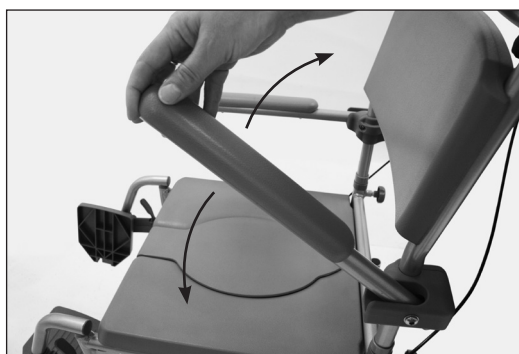

(Fig. 8)

Seat Operation

The seat is a horseshoe shape with removable cover for the aperture. When used as a shower chair, it is recommended that the aperture cover is removed to allow better access to the occupant for cleaning.

The seat clips on and off the frame. To remove the seat for cleaning, first remove the potty and aperture cover. Then lift up the front of the seat to release and slide the seat away from the chair. To attach the seat first locate the seat by sliding the back of the seat in to the frame, then press down on the whole of the seat until secure.

Commode Pan Operation

The commode pan is installed and removed by sliding the pan into the two sliders mounted to the underneath of the seat. To install, slide the pan underneath the seat from the rear of the chair, ensuring the pan sits on both sliders of the seat.

ENSURE NOBODY IS SAT ON THE CHAIR WHEN INSTALLING OR REMOVING THE PAN TO PREVENT ANY ENTRAPMENT.

Headrest Operation *Tilt-in-Space model only*

Insert the neck rest into the black bracket on the push bar, adjust to the correct position and tighten using the hand knob (see Fig.9). The depth of the headrest can be adjusted using the upper hand knob (see Fig.10).

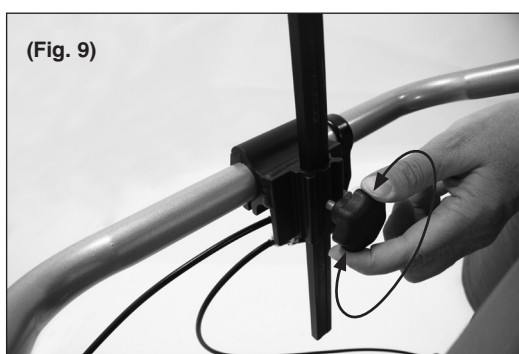

(Fig. 9)



(Fig. 10)

Tilting Operation *Tilt-in-Space model only*

The angle of the tilt-in-space chair can be adjusted using the handle adjustment at the rear of the chair. Squeeze the brake handle to release tension and adjust the chair accordingly. To remain in position, release the brake handle (**see Fig.11**).

ALWAYS ENSURE THE PATIENT IS COMFORTABLE AND SECURE WHEN TILTED.

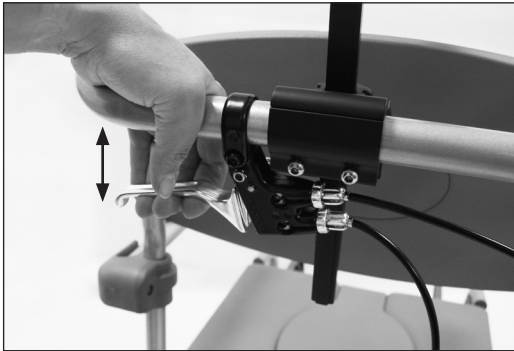

(Fig. 11)

Castor Operation

The castors can be locked so that the chairs cannot move forwards or reverse. To lock the castor press down on the locking tab with a foot. To release press the other side of the locking tab with a foot (**see Fig.12**).

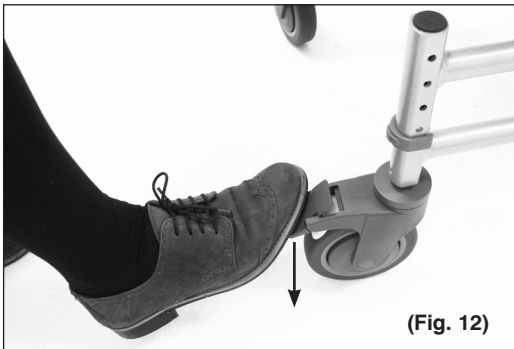

(Fig. 12)

LOCK



(Fig. 12a)

RELEASE

24" Wheel Operation

When the 24" rear wheels are installed, the chair can be propelled by either the attendant or the chair occupant. If the attendant is propelling the chair, they should propel the chair using the push handle at the rear and apply the castor brakes when the chair is stationary. If the occupant is propelling the chair, they should use the hand rims mounted on the side of the wheels to go, manoeuvre and stop and then apply the brakes when the chair is stationary.

To operate the brakes, push the brake lever forward to lock the wheel. Pull the brake lever back to release the brake (**see Fig.13**).

ENSURE BOTH BRAKES ARE APPLIED WHEN THE CHAIR IS STATIONARY AND WHEN THE USER IS SIDE TRANSFERRING.



LOCK

(Fig. 13)

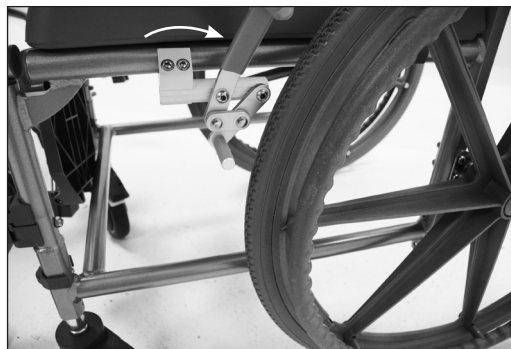

RELEASE

(Fig. 13a)

Height Adjustment Operation

On the attendant models (excluding the 842), the height can be adjusted by removing the e-clips from the base of the frame. Adjust the castor stem to the required position and insert the e-clip (**see Fig.14**). Repeat this process for the remaining three castors, ensuring all four castors are set at the same height.

PLEASE NOTE there are only three different height settings, do not set the castors to the highest setting which is indicated with a cross below in Fig.14c.

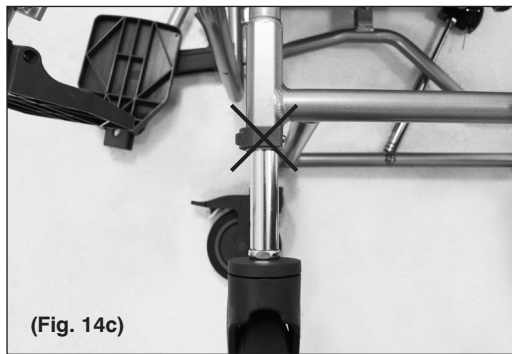
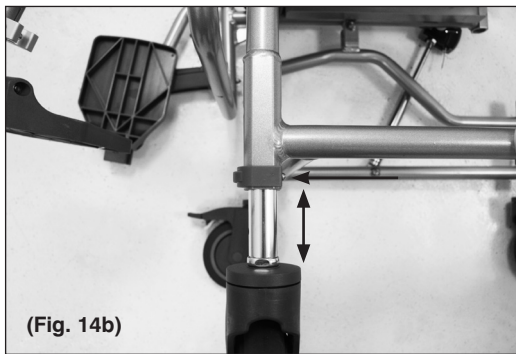
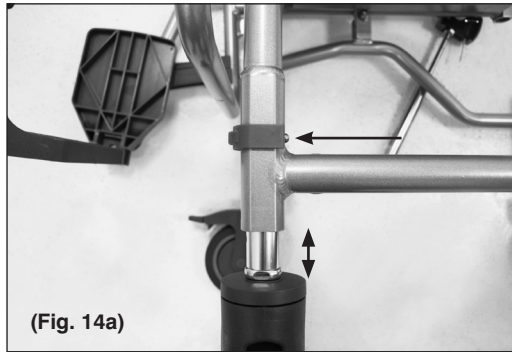
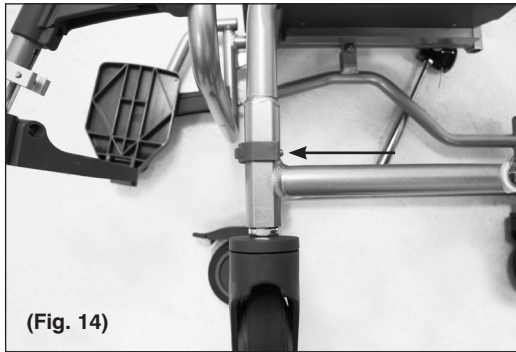

On the self-propelled models (excluding the 841), the height can be adjusted.

1. Remove the e-clips from the base of the front of the frame. Adjust the castor stem to the required position and insert the e-clip. Repeat this process for the remaining castor, ensuring both castors are set at the same height.
2. Adjust the rear 24" wheels by removing the two bolts from the axle bracket at the rear of the chair. Position the axle bracket at the correct height and reinsert the two bolts. Tighten the two bolts securely (**see Fig.15**), ensuring both wheels are fitted correctly.



(Fig. 15)



(Fig. 15a)

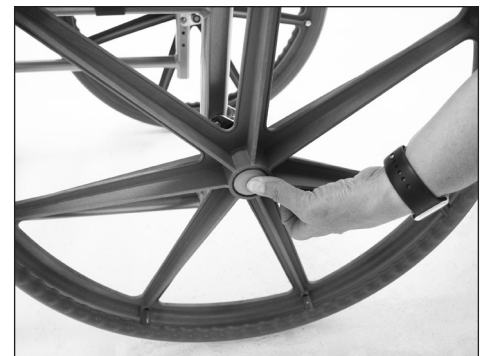

(Fig. 15b)

Care and Cleaning

To clean, wipe over with a soft damp cloth. Use general purpose neutral detergent and warm soapy water. The shower chair may be placed under running water at low pressure or showered down to assist cleaning. Do not use harsh abrasives or bleach based cleaners to avoid surface damage and discolouration. To disinfect clean as above and wipe over with solution of one thousand parts per million available chlorine disinfectant (haztabs/precept), rinse and dry.

Warranty

The Homecraft Deluxe Shower Commode Chairs are warranted for one year from the date of purchase against faulty workmanship or materials. Please contact your supplier/dealer should a fault occur. The warranty does not extend to the consequential costs resulting from fault clearance, in particular freight and travel costs, loss of earnings, expenses, etc. The manufacturer will not accept responsibility for any damage or injury caused by misuse or non-observance of the instructions set out above.

Please retain these instructions for future reference.

These user instructions are available in large print, please contact Performance Health Customer Services for a copy.
Please retain these instructions for future reference.



Performance Health International Ltd.

Nunn Brook Road, Huthwaite,
Sutton-in-Ashfield, Nottinghamshire,
NG17 2HU, UK.

UK:

Tel: 03448 730 035

Fax: 03448 730 100

www.performancehealth.co.uk

International:

Tel: +44 1623 448 706

Fax: +44 1623 448 784

Performance Health Supply, Inc.

W68 N158 Evergreen Blvd.

Cedarburg, WI 53012

USA

www.performancehealth.com

Performance Health ANZ

Unit 3, 3 Basalt Road,
Pemulwuy NSW, Australia 2145.

Tel: 1300 473 422

Fax: 1300 766 473

www.performhealth.com.au

Performance Health France

13 rue André Pingat

CS 10045

51724 Reims Cedex

France

Tel: 00(33) 03 10 00 79 30

Fax: 00(33) 03 54 70 04 34

www.performancehealth.fr



Homecraft™ is a trademark of Performance Health International Ltd.
